

INVITATION FOR BIDS/NIT

Tender No: CCFP/PUR/2K20/139

CSIR- National Aerospace Laboratories (NAL), Bengaluru, India is one of the premier laboratories under Council of Scientific and Industrial Research (CSIR), an autonomous body under Department of Scientific and Industrial Research, Government of India, New Delhi. CSIR-NAL is a Science and Knowledge based Research, Development and Consulting Organization. It is internationally known for its excellence in Scientific Research in Aerospace Engineering.

The Director, CSIR-NAL invites online quotation for procurement of the following item(s) for day to day research work.

| Sl.No. | Description of Items | Unit | Qty |
|--------|---|------|-----|
| 1 | Heat Setting Rollers (As per specification attached) | No | 1 |

| | |
|-----------------------------|--|
| Single / Double Bid | Single |
| Bid Security (EMD) (in INR) | Bid Securing Declaration Form to be submitted. |

01.Tender Documents May be downloaded from Central Public Procurement Portal <https://www.etenders.gov.in>. Aspiring Bidders who have not enrolled/ registered in e- procurement should enroll/ register before participating through the website <https://www.etenders.gov.in>. The portal enrolment is free of cost. Bidders are advised to go through instructions provided at 'Instructions for online Bid Submission'.

02.Tenderers can access tender documents on the website (For searching in the NIC site <https://www.etenders.gov.in>, kindly go to Tender Search option, select tender type and select ' Council of Scientific and Industrial Research' in organization tab and select NAL-Bengaluru-CSIR' in department type Thereafter, Click on "Search" button to view all CSIR-NAL, Bengaluru tenders). Select the appropriate tender and fill them with all relevant information and submit the completed tender document online on the website <https://www.etenders.gov.in> as per the schedule given in the next page.

03.Either the Indian Agent on behalf of the Foreign principal or the Foreign principal can bid directly in a tender but not both. However, the offer of the Indian Agent should also accompany the authorization letter from their principal. To maintain sanctity of tendering system, one Indian Agent cannot represent two different foreign principals in one tender.

04.Unsolicited / conditional / unsigned tenders (Quotations) **shall not** be considered. Quotations received after the due date and time **shall be summarily rejected**.

05.The amount of the Performance **Security** shall be **3% of the contract value** to be submitted within 21 days from the date of Purchase Order valid up to 60 days after the date of completion of performance obligations including warranty obligations.



पी बी सं. 1779, एचएएल एयरपोर्ट रोड , बेंगलूर- 560 017, भारत,

P B No 1779, HAL Airport Road, Bengaluru - 560 017, INDIA

फोन / Phone : (का./ Off) : +91 - 80 - 2508 6097 / 6710, फैक्स / FAX : +91-80-2526 9611



06.The Bidder shall comply the terms and conditions of the tender, failing which; the offer shall be liable for rejection.

07.The Director, CSIR- National Aerospace Laboratories, Bengaluru reserves the right to accept any or all the tenders either in part or in full or to split the order without assigning any reasons there for.



Raman Kumar
Stores & Purchase Officer
For & Behalf of CSIR-NAL

SPECIFICATION FOR HEAT SETTING ROLLERS

1.0 Scope of the vendor:

Design, fabrication, supply, erection and commissioning for Heat setting rollers. Vendor to check for the completeness of his system to meet the process requirements and guarantee the performance parameter as specified herein. The operational guarantee for the equipment supplied shall be provided by the vendor.

2.0 Equipment duty and mode of operation:

This equipment is used for heat setting of polyacrylonitrile (PAN) fibers in the fiber spinning line. The mode of operation for this equipment will be continuous in nature.

3.0 Brief description of the Equipment:

This equipment is used for in the fiber line for heat setting of PAN fibers. The heat setting is done by exposing PAN fiber to higher temperature than its hot stretch temperature for few seconds. The unit operates in two configuration mode as shown in drawing (section 5).This heat setting is done either at constant speed or some shrinkage in fibers. The design parameters for the equipment are as given below. This equipment as shown in schematic drawings (section 5.0) has two electrically heated rollers. The maximum temperature of these rollers could be 250 C. One of them roller will be fixed and other will be a skewed roller to adjust the gap between the moving fibers overs these rollers.

In case of desired shrinkage, another two non-heated skewed idlers are also fixed on sides. In shrinkage arrangement the fiber will make few passes over top roller and skewed idler and then it passes to bottom roller and idler to make few more passes. In this arrangement, the bottom roller rotates at little lower speed to provide shrinkage to the fibers. All the rollers idlers are placed inside an insulated chamber with slit opening for fiber inlet and outlet. A hot air blower/fan is also required to keep hot air recirculation inside the chamber.

The unit would be able to operate in both the configuration as shown in schematic Drawing(section 5).

4.0 Specification of equipment

- 1) Material of construction for rollers: stainless steel 316 with mirror polish
- 2) Stainless steel rollers: Skewed type to adjust angle between rollers
- 3) Inside of the unit : Stainless steel sheet
- 4) A door at front of the unit (Transparent view)
- 5) SS Roller maximum temperature : 250 C
- 6) SS Roller Max speed : 100 meter/min
- 7) SS Roller diameter and length : 200 mm and 350 mm



- 8) SS Idler diameter and length : 75 mm 350 mm
- 9) SS Roller drive: Servo type
- 10) Thermal insulation of the unit: Yes (cladding or compact type)
- 11) Fiber entry point (One Number): Slit type at height of **1620 mm** from ground
- 12) Fiber exit point (Two Number): Slit type
- 13) Hot air circulation blower: Yes
- 14) Process control: A small control panel is to be provided with following process control parameter.
 - a) First Servo drive speed control (optional terminal for 4-20mA external set point)
 - b) Second Servo drive speed control (optional terminal for 4-20mA external set point)
 - c) First SS roller heating control
 - d) Second SS roller heating control
 - e) Hot air blower temperature control (Max temp 250)
 - f) ON/OFF button with glow light for both servo motors
 - g) ON/OFF button with glow light for both servo motors
 - h) ON/OFF button with glow light for Blower and heater

5.0 Schematic drawing of equipment

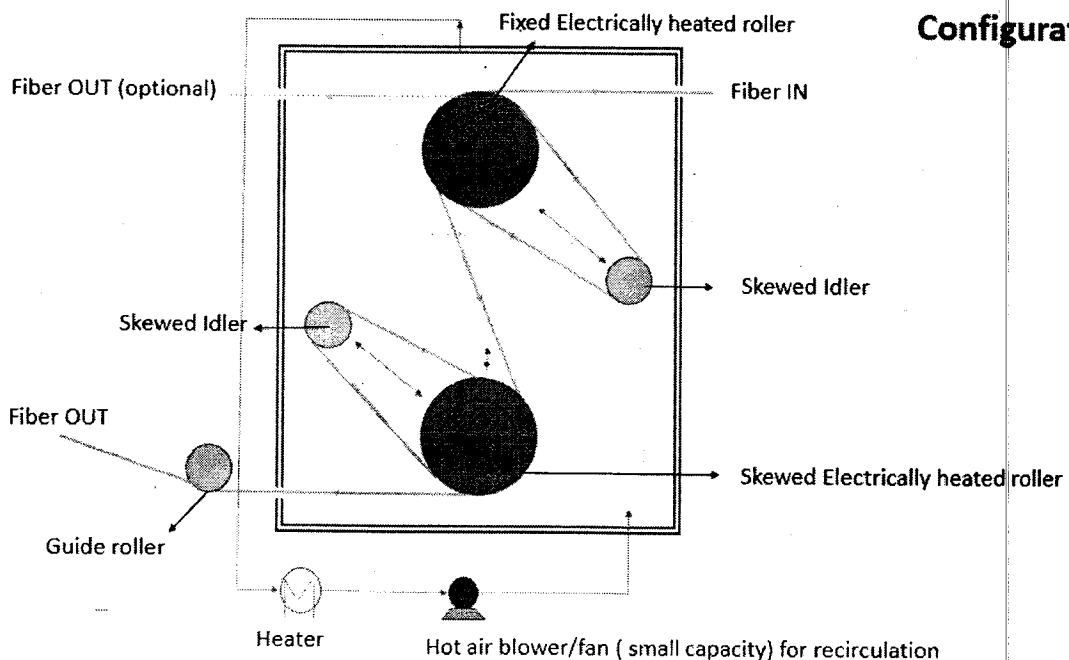

Configuration : 1

[Handwritten signature]

Configuration : 2

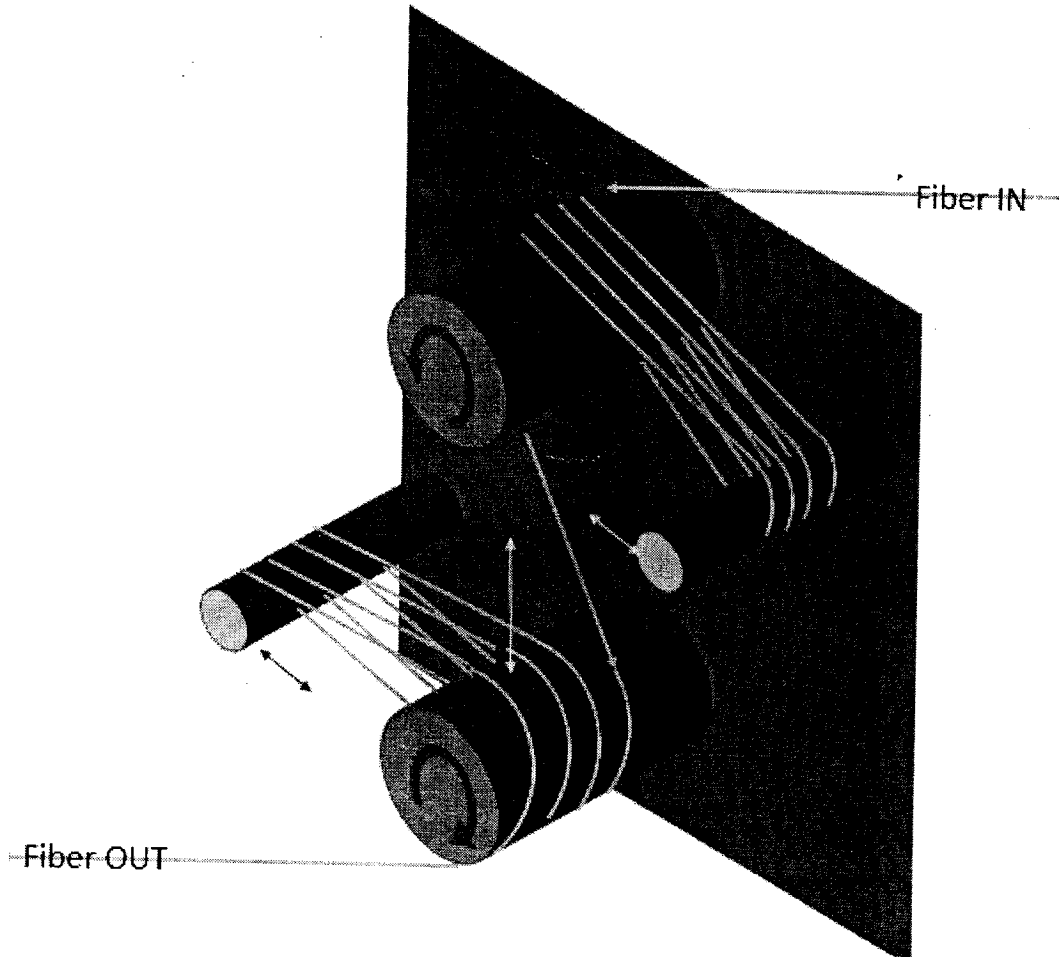
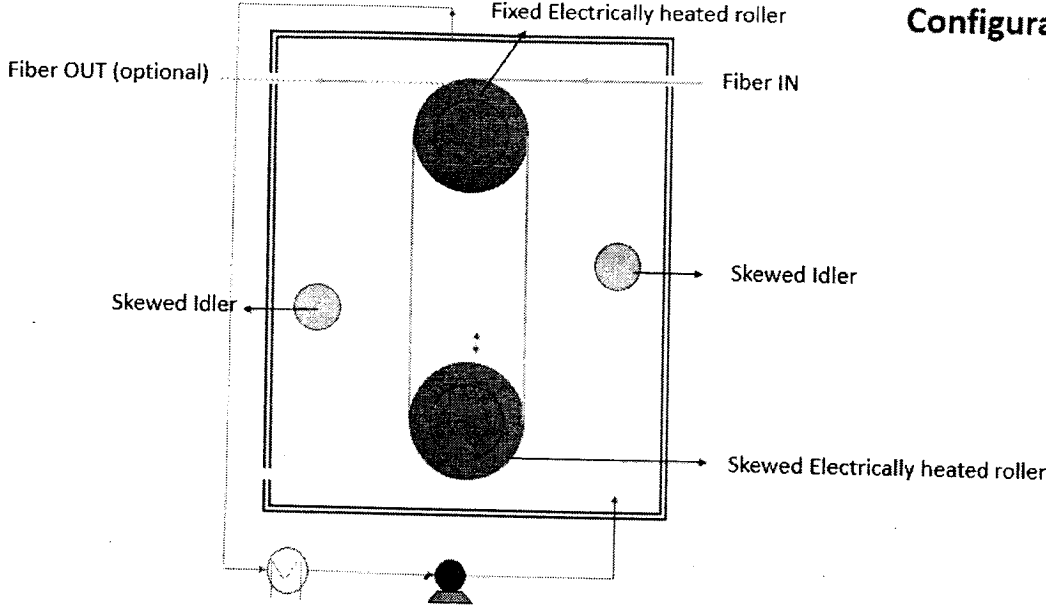

6.0 General requirement

- a) The equipment will be located on the first floor.

- b) Vendor should submit along with his offer the detailed specifications and the standard make of the motor, gear box and other bought out items.
- c) Vendor should submit test certificate, performance data and warranty certificate from the OEM for all bought out items.
- d) Vendor has to submit the drawing for approval before commencement of fabrication.
- e) Servo drive for SS roller should be standard make (e.g. Schneider, Panasonic, or equivalent make)
- f) Vibration free rotation of the rollers: The rollers for the fiber forwarding rollers should be smooth in running within a permissible vibration limit of 1.12 mm/s max vibration.
- g) Eccentricity motion free rollers: The motor driven roller for fiber forwarding should not have any unbalance around the axis of rotation which could create eccentric/wobbling motion. The permissible limit for eccentricity along the axis of rotation should be 0.1 mm max.

7.0 Scope of supply:

- a) A complete unit as shown in drawing along with process control panel.
- b) 2 nos. of Stainless steel rollers (skewed type) with 2 nos. of stainless steel idler (skewed type)
- c) Control panel for equipment operation (Both SS roller speed, Both SS roller temperature, Hot air Temperature)
- d) Thermally insulated unit for the heated rollers with recirculated hot air unit (Electrical heater with a blower)
- h) A guide roller for guiding the exit fiber to the winder.
- i) A rigid structure for the unit with height adjustable vibration pads.
- j) Internal Wiring of equipment and control panel.
- k) Heated roller cover guard for safety .

8.0 Exclusion :

- a) All electrical wiring from Distributed controls system to field.

9.0 Delivery :

The items are to be delivered at CCFP, NAL ,Belur Campus.

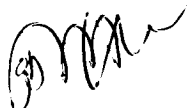

Terms & Condition

| | |
|---------------------------------------|--|
| Delivery Term | FOR- NAL |
| Delivery Schedule | Within 60 days from the date of PO |
| GST (Goods) | Extra @ 5% against Concessional GST Exemption Certificate |
| GST (Service/AMC) | Extra @18%.TDS as per rules. |
| Payment Term | NAL Term (Payment would be made within 30 days, only after receipt of material in good conditions, inspection and acceptance by end user). |
| Payment Term (for AMC) | Quarterly/half yearly/yearly on certification by end user based on scope of AMC |
| Installation & Commissioning (if any) | |
| Training (if any) | |
| Warranty Certificate (if any) | |
| Any other Certificates (if any) | |

CCFP/PUR/2K20/139

SCHEDULE CUM CRITICAL DATE SHEET

| | | | |
|----|---|---|----------|
| 1 | Name of Organization | CSIR-National Aerospace Laboratories, Bengaluru | |
| 2 | Tender Reference No | CCFP/PUR/2K20/139 | |
| 3 | Tender Type (Open/Limited/EOI/Auction/Single) | Open Tender | |
| 4 | Type/Form of Contract (Work / Supply / Auction / Service / Buy / Empanelment / Sell) | Supply | |
| 5 | No of Covers (One/Two/Three/Four) | One | |
| 6 | Tender Category (Services/Good/Works) | Good | |
| 7 | Allow Resubmission (Only in online mode within scheduled period) | Yes | |
| 8 | Allow Withdrawal (Only in online mode within scheduled period) | Yes | |
| 9 | Allow Offline Submission | No | |
| 10 | Work Item Title | Heat Setting Rollers | |
| 11 | Work Description | Heat Setting Rollers (As per specification attached) | |
| 12 | Delivery Schedule | 60 days from the date of Purchase Order | |
| 13 | Product Category (Civil Works / Electrical Works / Fleet Management / Computer Systems) | R & D Equipment | |
| 14 | Is Multi Currency Allowed | No | |
| 15 | a) Tender Publishing Date - | 20 Jan 2021 | 1800 Hrs |
| | b) Document download start Date: | 20 Jan 2021 | 1800 Hrs |
| | c) Bid Submission Start Date | 20 Jan 2021 | 1800 Hrs |
| | d) Bid Submission End Date- | 11 Feb 2021 | 1000 Hrs |
| | e) Bid Opening Date- | 12 Feb 2021 | 1100 Hrs |
| 16 | Bid Validity Days | 90 days | |
| 17 | Address for communication | Stores and Purchase Officer CSIR-National Aerospace Laboratories, HAL Airport Road, Kodihalli, Bengaluru - 560017 | |
| 18 | Inviting Officer | Director, CSIR-NAL | |
| 19 | Contact No | 25086097, 25086710 | |
| 20 | E-mail Address | purchasecadd@nal.res.in/spo@nal.res.in | |
| 21 | Detailed specification of item | Invitation for bids / NIT | |
| 22 | Tender Terms & Conditions & Instruction for online bid submission | The prospective bidders are requested to refer to the Standard Tender Document available on NAL internet(www.nal.res.in) under the icon Tender-Purchase before formulating and submitting their bids. | |

Bid-Securing Declaration Form

Date: _____

Bid No. _____

To (insert complete name and address of the purchaser)

I/We, The undersigned, declare that:

I/We understand that, according to your conditions, bids must be supported by a Bid Securing Declaration.

I/We accept that I/We may be disqualified from bidding for any contract with you for a period of one year from the date of notification if I am /We are in a breach of any obligation under the bid conditions, because I/We

| | |
|----|--|
| a) | have withdrawn/modified/amended, impairs or derogates from the tender, my/our Bid during the period of bid validity specified in the form of Bid; or |
| | Having been notified of the acceptance of our Bid by the purchaser during the period of bid validity |
| b) | I. fail or reuse to execute the contract, if required, or II. fail or refuse to furnish the Performance Security, in accordance with the Instructions to Bidders. |

I/We understand this Bid Securing Declaration shall cease to be valid if I am/we are not the successful Bidder, upon the earlier of (i) the receipt of your notification of the name of the successful Bidder; or (ii) thirty days after the expiration of the validity of my/our Bid.

Signed: (insert signature of person whose name and capacity are shown) in the capacity of (insert legal capacity of person signing the Bid Securing Declaration).

Name: (insert complete name of person signing the Bid Securing Declaration)

Duly authorized to sign the bid for an on behalf of: (insert complete name of Bidder) Dated

on _____ day of _____ (insert date of signing)

Corporate Seal (where appropriate)

Note:

1. In case of a Joint Venture, the Bid Securing Declaration must be in the name of all partners to the Joint Venture that submits the bid)
2. Bid Security declaration must be signed in by the Proprietor/CEO/MD or equivalent level of Officer of the company.

Tender No.:

PERFORMANCE SECURITY FORM/STAND-BY LETTER OF CREDIT

MODEL BANK GUARANTEE FORMAT FOR PERFORMANCE SECURITY/ STAND-BY LETTER OF CREDIT

To,
.....

WHEREAS (name and address of the supplier) (hereinafter called "the supplier") has undertaken, in pursuance of contract No. datedto supply (description of goods and services) (herein after called "the contract").

AND WHEREAS it has been stipulated by you in the said contract that the supplier shall furnish you with a bank guarantee by a scheduled commercial bank recognized by you for the sum specified therein as security for compliance with its obligations in accordance with the contract;

AND WHEREAS we have agreed to give the supplier such a bank guarantee;

NOW THEREFORE we hereby affirm that we are guarantors and responsible to you, on behalf of the supplier, up to a total of (amount of the guarantee in words and figures), and we undertake to pay you, upon your first written demand declaring the supplier to be in default under the contract and without cavil or argument, any sum or sums within the limits of (amount of guarantee) as aforesaid, without your needing to prove or to show grounds or reasons for your demand or the sum specified therein.

We hereby waive the necessity of your demanding the said debt from the supplier before presenting us with the demand.

We further agree that no change or addition to or other modification of the terms of the contract to be performed there under or of any of the contract documents which may be made between you and the supplier shall in any way release us from any liability under this guarantee and we hereby waive notice of any such change, addition or modification.

This guarantee shall be valid until the day of, 20.....

(Signature of the authorized officer of the Bank)

.....
Name and designation of the officer

.....
Seal, Name & Address of the Issuing Branch of the Bank

Note:
Whenever the bidder chooses to submit the Performance Security in the form of Bank Guarantee, then he should advise the banker issuing the Bank Guarantee to immediately send by Registered Post A.D. an unstamped duplicate copy of the Guarantee directly to the Purchaser with a covering letter to compare with the original BG for the correctness, genuineness, etc.