



TENDER NO: APMF/PUR/2K19/170

Date: 20-July-2021

TENDER DOCUMENT

FOR

**PROCUREMENT OF CNC SERVO HYDRAULIC PRESS BRAKE
WITH ACCESSORIES**

**COUNCIL OF SCIENTIFIC AND INDUSTRIAL RESEARCH
NATIONAL AEROSPACE LABORATORIES
PB NO.1779, HAL AIRPORT ROAD, BENGALURU – 560017
KARNATAKA-INDIA**



Council of Scientific and Industrial Research
National Aerospace Laboratories
PB No.1779, HAL Airport Road, Bengaluru – 560 017, Karnataka-India
Tel #: 00 91 80 2508 6097/6710
E-mail: purchasecadd@nal.res.in
Website: www.nal.res.in

Invitation for e-Bids / Notice Inviting e-Tender

CSIR- National Aerospace Laboratories (NAL), Bengaluru, India is one of the premier laboratories under Council of Scientific and Industrial Research, an autonomous body under Department of Scientific and Industrial Research (Government of India), New Delhi. CSIR-NAL is a Science and Knowledge based Research, Development and Consulting Organization. It is internationally known for its excellence in Scientific Research in Aerospace Engineering.

The Director, CSIR-NAL invites sealed bids from their Manufacturers, their distributors and Indian Agent of Foreign Principals, if any, for the procurement of the following Goods/Services for its day-to-day research. The Technical specifications, allied requirements and scope of supply are given in **Chapter 4** appended herewith.

Sr. No.	Tender No.	Brief Description of item(s)	Unit	Quantity	Single / Two Bid
1	APMF/PUR/2K19/170	Procurement of CNC Servo Hydraulic press brake with accessories	Details as per Chapter-4 and BoQ		Two

1. Interested Bidders may obtain further information from the office of the:
Sr. Controller of Stores & Purchase
Purchase Section
CSIR- National Aerospace Laboratories
PB No.1779, HAL Airport Road, Kodihalli, Bengaluru – 560017
Karnataka-India
Tel #: 080 2508 6097/6710
E-mail: purchasecadd@nal.res.in
2. E-Bids are invited through the electronic tendering process and the Tender Document can be downloaded from the e-Tender Central Public Procurement Portal (CPPP) of Government of India, <https://etenders.gov.in>. **The submission of e-Bids will be only through the e-Tender portal <https://etenders.gov.in>. Bids will not be accepted in any other form.**
3. The prospective bidders should adhere to deadlines specified in Tender Details Screen corresponding to this Tender on E-Tender portal <https://etenders.gov.in>.
4. (a) A Pre-Bid Conference will be held on schedule as mentioned below.

	Date	Time in hours (IST)	Venue
Pre-Bid Conference	Not Applicable		
Bidders desirous of attending Pre-bid meeting are required to provide the following details: -			
1. Bidders Name & address			
2. Name, designation & mobile number of the representative (s) attending the meeting.			
3. E-mail ID to which the meeting invitation to be sent.			
4. Pre-bid queries, if any.			
The above information should be sent by e-mail to purchasecadd@nal.res.in on or before.....			

(b) Queries received after pre-bid will not be considered.

5. The Bid prepared by the Bidder shall include the following: -

Bid Security (BS) / Earnest Money Deposit (EMD)	
a)	EMD Amount: NIL BIDDER TO SUBMIT BID SECURING DECLARATION. [Refer Annexure-B, Chapter -8]
b)	The Bid Security Declaration in the name of “ The Director, National Aerospace Laboratories, Bengaluru ” to be part of the Technical Bid , failing which the bid is liable to be rejected. For further details, refer Tender document.
c)	Forms as specified in Chapter No.8

6. The Schedule for Submission of e-Bids and Opening of e-Bids is as follows: -

Date & Time of Submission of e-Bid		Date and Time of Opening of e-Bid		Venue
Date	Time (IST)	Date	Time (IST)	As detailed at Sr. No.1
12 Aug 2021	10:00 Hrs	13 Aug 2021	11:00 Hrs	

7. As per Govt. of India procurement policies:

(a)	The purchaser intends to give purchase preference to local suppliers* in case the cost of procurement is up to Rs.50.00 lakhs.
(b)	The procuring entity intends to give purchase preference to products/goods manufactured by micro, small and medium enterprises.

Local Content, Class-I local Supplier, Class-II Supplier, Non-Local Supplier, L1, Margin of Purchase Preference is as per DIPP Order or by the Competent Ministries/Departments as and when issued.

* “Local supplier” means a supplier or service provider whose product or service offered for procurement meets the minimum local content of 50% as prescribed in DIPP Order No. P-45021/2/2017-PP (BE-II) dated 4th July 2020 or by the competent Ministries/Departments in pursuance of this order.

‘Local content’ means the amount of value added in India which shall, unless otherwise prescribed by the Nodal Ministry, be the total value of the items procured (excluding net domestic indirect taxes) minus the value of imported content in the item (including all customs duties) as a proportion of the total value, in percent.

MoF Orders are also applicable as modified from time to time by the concerned authority.

8. In case of agents quoting in offshore procurements, on behalf of their principal manufacturers, one agent cannot represent two manufacturers or quote on their behalf in a particular tender enquiry. One manufacturer can also authorize only one agent/ dealer. There can be only one bid from the following:

i)	The Principal manufacturer directly or through one Indian agent on his behalf; and
ii)	Indian/foreign agent on behalf of only one principal.

9. The bidders proposing to supply finished products directly/indirectly from Bidders of Countries sharing the land border with India should submit copy of registration done with the Ministry of Home Affairs and Ministry of External Affairs.

10. If the products supplied are not from Bidders of Countries sharing Land border with India, the Bidders should enclose a declaration. The bids of those bidders failing to comply with the above clauses will be summarily rejected.

11. The Director, CSIR-National Aerospace Laboratories (NAL), Bengaluru, India reserves the right to accept or reject any bids or accept all tenders either in part or in full or to split the order, or to annul the bidding process without assigning any reasons there for.

General Instructions to Bidders: -

01. Tender Documents may be downloaded from Central Public Procurement Portal <https://www.etenders.gov.in>. Aspiring Bidders who have not enrolled/ registered in e- procurement should enroll/ register before participating through the website <https://www.etenders.gov.in>. The portal enrolment is free of cost. Bidders are advised to go through instructions provided at 'Instructions for online Bid Submission'.
02. Tenderers can access tender documents on the website (For searching in the NIC site <https://www.etenders.gov.in>, kindly go to Tender Search option, select tender type and select ' Council of Scientific and Industrial Research' in organization tab and select NAL-Bengaluru-CSIR' in department type Thereafter, Click on "Search" button to view all CSIR-NAL, Bengaluru tenders). Select the appropriate tender and fill them with all relevant information and submit the completed tender document online on the website <https://www.etenders.gov.in> as per the schedule given in the next page.
03. The Bidders should have Java 8 update 231 version-32 bit for uploading the bid in the CPP Portal.

INDEX

Chapter	Content	Page No.
1	Instructions to Bidders	06-24
2	General and Special Conditions of Contract	25-38
3	Schedule of Requirement	39
4	Specifications and Allied Technical Details	40-48
5	Price Schedule Forms	49
6	Qualification Requirements	50-52
7	Contract Form	53
8	Other Forms	54-70

CRITICAL DATE SHEET

Sl. No.	Stage	Date	Time Hrs
1.	Publish Date & Time	20-Jul-2021	18:00
2.	Sale/document Download Start Date & Time	20-Jul-2021	18:00
3.	Last Date & time for receipt of queries	05-Aug-2021	14:00
4.	Pre-bid Conference, if any	Not Applicable	
5.	Bid Submission Start Date & time	20-Jul-2021	18:00
6.	Bid Submission End Date & Time	12-Aug-2021	10:00
7.	Bid Opening Date & Time	13-Aug-2021	11:00

CHAPTER - 1

INSTRUCTIONS TO BIDDERS-Table of Contents

Clause No.	Contents
A. Introduction	
1.1	Eligible Bidders
1.2	Cost of Bidding
1.3	Code of Integrity
B. The Bidding Documents	
1.4	Cost of tender Documents
1.5	Content of tender Documents
1.6	Clarification of tender documents
1.7	Amendment of tender Documents
C. Preparation of Bids	
1.8	Language of Bid
1.9	Purchase Preference Policies
1.10	Documents Comprising the Bid
1.11	Bid form and price schedule
1.12	Bid Prices
1.13	Bid Currencies
1.14	Documents Establishing Bidder's Eligibility and Qualifications
1.15	Documents Establishing Goods' Eligibility And Conformity to Bidding Documents
1.16	Bid Security
1.17	Period of Validity of Bids
1.18	Format and Signing of Bid
D. Submission and Sealing Bids	
1.19	Submission, Sealing and Marking of Bids
1.20	Deadline for Submission of Bids
1.21	Late Bids
1.22	Withdrawal, substitution and Modification of Bids
E. Opening and Evaluation of Bids	
1.23	Opening of Bids by the Purchaser
1.24	Confidentiality
1.25	Clarification of Bids
1.26	Preliminary Examination
1.27	Bidders right to question rejection
1.28	Responsiveness of Bids
1.29	Non-Conformity, Error and Omission
1.30	Examination of Terms & Conditions, Technical Evaluation
1.31	Conversion to Single Currency
1.32	Evaluation and Comparison of bids
1.33	Contacting the Purchaser
1.34	Post qualification
F. Award of Contract	
1.35	Negotiations
1.36	Award Criteria
1.37	Purchaser's right to vary Quantities at Time of Award
1.38	Option Clause
1.39	Purchaser's right to accept any Bid and to reject any or all Bids
1.40	Notification of Award
1.41	Signing of Contract
1.42	Order Acceptance
1.43	Performance Security
1.44	Pre-bid Conference
1.45	Integrity Pact
1.46	Assistance to Bidders

A Introduction

Instructions to bidder are broad guidelines to be followed while formulating the bid and its submission to the Purchaser. It also describes the methodology for opening and evaluation of bids and consequent award of contract.

1.1. Eligible Bidders

- 1.1.1 This Invitation for Bids is open to all suppliers' **subject to para 07** of the invitation for e-Bids/NIT.
- 1.1.2 A supplier or bidder shall be considered to be from a country if (i) the entity is incorporated in that country, or ii) a majority of its shareholding or effective control of the entity is exercised from that country; or (iii) more that 50% of the value of the item being supplied has been added in that country. Indian suppliers shall mean those entities which meet any of these tests with respect to India.
- 1.1.3 MSEs would be treated as owned by Scheduled Caste/Schedule Tribe enterprises as under:

(a)	In case of proprietary MSE, proprietor(s) shall be SC/ST.
(b)	In case of partnership MSE, the SC/ST partners shall be holding at least 51% (Fifty One percent) shares in the unit.
(c)	In case of Private Limited Companies, at least 51% (fifty one percent) share shall be held by SC/ST promoters.

- 1.1.4 MSEs owned by women shall also be determined as per the above analogy/criteria.
- 1.1.5 Bidders should not be associated, or have been associated in the past, directly or indirectly, with a firm or any of its affiliates which have been engaged by the Purchaser to provide consulting services for the preparation of the design, specifications, and other documents to be used for the procurement of the goods to be purchased under this Invitation of Bids.
- 1.1.6 Bids from Joint Ventures, Consortium or Associations so long as they are formed and registered prior to the bid submission date.
- 1.1.7 The bidders who have been temporarily suspended or removed from the list of registered suppliers by the purchaser or banned from Ministry/country wide procurement **shall be ineligible** for participation in the bidding process.

1.2 Cost of Bidding

- 1.2.1 The Bidder shall bear all costs associated with the preparation and submission of its bid, and "the Purchaser", will in no case be responsible or liable for these costs, regardless of the conduct or outcome of the bidding process.

1.3 Code of Integrity

- 1.3.1 The bidders/suppliers should sign a declaration about abiding by the Code of Integrity for Public Procurement in bid documents. In case of any transgression of this code, the bidder is not only liable to be removed from the list of registered suppliers, but it would be liable for other punitive actions such as cancellation of contracts, banning and blacklisting or action in Competition Commission of India, and so on.
- 1.3.2 **Code of integrity for Public Procurement:** The Purchaser as well as bidders, suppliers, contractors and consultants should observe the highest standard of ethics and should not indulge in the following prohibited practices, either directly or indirectly, at any stage during the procurement process or during execution of resultant contracts:

i)	"Corrupt practice"	making offers, solicitation or acceptance of bribe, rewards or gifts or any material benefit, in exchange for an unfair advantage in the procurement process or to otherwise influence the procurement process or contract execution;
ii)	"Fraudulent practice"	any omission or misrepresentation that may mislead or attempt to mislead so that financial or other benefits may be obtained or an obligation avoided. This includes making

		false declaration or providing false information for participation in a tender process or to secure a contract or in execution of the contract;
iii)	“anti-competitive practice”	any collusion, bid rigging or anti-competitive arrangement, or any other practice coming under the purview of the Competition Act, 2002, between two or more bidders, with or without the knowledge of the purchaser, that may impair the transparency, fairness and the progress of the procurement process or to establish bid prices at artificial, non-competitive levels;
iv)	“coercive practice”	harming or threatening to harm, persons or their property to influence their participation in the procurement process or affect the execution of a contract;
v)	“conflict of interest”:	participation by a bidding firm or any of its affiliates that are either involved in the consultancy contract to which this procurement is linked; or if they are part of more than one bid in the procurement; or if the bidding firm or their personnel have relationships or financial or business transactions with any official of purchaser who are directly or indirectly related to tender or execution process of contract; or improper use of information obtained by the (prospective) bidder from the purchaser with an intent to gain unfair advantage in the procurement process or for personal gain; and
vi)	“Obstructive practice”	materially impede the purchaser’s investigation into allegations of one or more of the above mentioned prohibited practices either by deliberately destroying, falsifying, altering; or by concealing of evidence material to the investigation; or by making false statements to investigators and/or by threatening, harassing or intimidating any party to prevent it from disclosing its knowledge of matters relevant to the investigation or from pursuing the investigation; or by impeding the purchaser’s Entity’s rights of audit or access to information;

1.3.3 **Obligations for Proactive disclosures**

i)	The Purchaser as well as bidders, suppliers, contractors and consultants, are obliged under Code of Integrity for Public Procurement to sue-moto proactively declare any conflicts of interest (coming under the definition mentioned above – pre-existing or as and as soon as these arise at any stage) in any procurement process or execution of contract. Failure to do so would amount to violation of this code of integrity; and
ii)	The bidder must declare, whether asked or not in a bid document, any previous transgressions of such a code of integrity with any entity in any country during the last three years or of being debarred by any other Procuring Entity. Failure to do so would amount to violation of this code of integrity;
iii)	To encourage voluntary disclosures, such declarations would not mean automatic disqualification for the bidder making such declarations. The declared conflict of interest would be evaluated and mitigation steps, if possible, taken by the purchaser.

1.3.4 **Punitive Provisions**

Without prejudice to and in addition to the rights of the Purchaser to other penal provisions as per the bid documents or contract, if the Purchaser comes to a conclusion that a (prospective) bidder/supplier, directly or through an agent, has violated this code of integrity in competing for the contract or in executing a contract, the purchaser may take appropriate measures including one or more of the following:

i)	If bids are under consideration in any procurement:	
	a)	Forfeiture or encashment of bid security;
	b)	Calling off of any pre-contract negotiations; and
	c)	Rejection and exclusion of the bidder from the procurement process.

ii)	If a contract has already been awarded	
	a)	Cancellation of the relevant contract and recovery of compensation for loss incurred by the purchaser;
	b)	Forfeiture or encashment of any other security or bond relating to the procurement;
	c)	Recovery of payments including advance payments, if any, made by the purchaser along with interest thereon at the prevailing rate.
iii)	Provisions in addition to above:	
	a)	Removal from the list of registered suppliers and banning/debarment of the bidder from participation in future procurements of the purchaser for a period not less than one year;
	b)	In case of anti-competitive practices, information for further processing may be filed under a signature of the Joint Secretary level officer, with the Competition Commission of India;
	c)	Initiation of suitable disciplinary or criminal proceedings against any individual or staff found responsible.

B. The Bidding Documents

1.4 Cost of Tender Documents

- 1.4.1 The bidding documents are to be **downloaded Free of Cost** from the website of **CPP Portal** <https://etenders.gov.in> or www.nal.res.in.

1.5 Content of Tender Documents

- 1.5.1 The goods required, bidding procedures and contract terms are prescribed in the bidding documents which should be read in conjunction. The bidding documents, apart from the invitation for bids and Critical Date Sheet have been divided into 8 Chapters as under:

Chapter No.	Name of the Chapter	
1	Instructions to Bidder (ITB)	
2	General Conditions of Contract (GCC) and Special Condition of Contract (SCC)	
3	Schedule of Requirements	
4	Specifications and Allied Technical Details	
5	Price Schedule Forms	
6	Qualification requirements	
7	Contract Form	
8	Other Standard Forms comprising	
	(i)	Bid Security Form
	(ii)	Bid Securing declaration
	(iii)	Bidder Information Form
	(iv)	Manufacturer's Authorization Form (MAF);
	(v)	Performance Statement form
	(vi)	Service Support details;
	(vii)	Format for declaration by the bidder for code of integrity and conflict of interest
	(viii)	Deviation Statement Form;
	(ix)	Bid form
	(x)	Performance Security Form;
	(xi)	Acceptance Certificate Form
	(xii)	Integrity pact

- 1.5.2 The Bidder is expected to examine all instructions, forms, terms, and specifications in the bidding documents. Failure to furnish all information required by the bidding documents or submission of a bid not substantially responsive to the bidding documents in every respect will be at the Bidder's risk and may result in rejection of its bid.

1.6 Clarification of tender documents

- 1.6.1 A prospective Bidder requiring any clarification of the Bidding Documents shall contact the Purchaser in writing at the Purchaser's address specified in the Special Conditions of Contract (SCC), latest by the date specified in the critical date sheet. No request for clarification or query shall normally be entertained after the deadline/pre-bid conference if any. Should the Purchaser

deem it necessary to amend the Tender Documents as a result of a clarification, it shall do so following the procedure under Clause relating to amendment of Tender Documents and Clause relating to Deadline for Submission of Bids.

- 1.6.2 The queries, clarifications and amendments issued would also be hosted on the website of the **CPP Portal/Purchaser** for the benefit of the other prospective bidders and also shall be sent to all bidders who have purchased the tender documents.

1.7 [Amendment of Tender Documents](#)

- 1.7.1 At any time prior to the deadline for submission of bids, the Purchaser may, for any reason, whether at its own initiative or in response to a clarification requested by a prospective bidder, modify the tender documents by amendment. The same would also be hosted on the website of the **CPP Portal/Purchaser** and all prospective bidders are expected to surf the website before submitting their bids to take cognizance of the amendments.

- 1.7.2 All prospective bidders who have down loaded the Tender Document should surf website of **CPP Portal/Purchaser** from time to time to know about the changes / modifications in the Tender Document. The changes / modifications would also be hosted on the website of **CPP Portal/Purchaser**. All prospective bidders are expected to surf the website of **CPP Portal/Purchaser** before formulating and submitting their bids to take cognizance of the amendments.

- 1.7.3 In order to allow prospective bidders' reasonable time in which to take the amendment into account in preparing their bids, the Purchaser, at its discretion, may extend the deadline for the submission of bids and host the changes on the website of **CPP Portal/Purchaser**.

C. [PREPARATION OF BIDS](#)

1.8. [Language of Bid](#)

- 1.8.1 The bid prepared by the Bidder, as well as all correspondence and documents relating to the bid exchanged by the Bidder and the Purchaser shall be written in English language only.

- 1.8.2 The Bidder/Supplier shall bear all costs of translation, if any, to the English language and bear all risks of the accuracy of such translation, for documents provided by the Bidder/Supplier.

1.9 [Purchase Preference Policies](#)

- 1.9.1 The purchaser intends to give product reservation/purchase preference/price preference in line with current Govt. of India procurement policies to help inclusive national economic growth by providing long term support to Small and Medium enterprises (SMEs) and disadvantaged sections of the society and to address environmental concerns along with preferential market access in govt. procurements.

- 1.9.2 For the above purpose, local supplier means a supplier or service provider whose product or service offered for procurement meets the minimum local content as prescribed in DIPP Order No. P-45021/2/2017-PP (BE-II) dated 28th May, 2018 or by the competent Ministries/Departments in pursuance of this order and local content means the amount of value added in India which shall, unless otherwise prescribed by the Nodal Ministry, be the total value of the items procured (excluding net domestic indirect taxes) minus the value of imported content in the item (including all customs duties) as a proportion of the total value, in percent.

1.10.1 [Documents comprising the E-bid](#)

The bid prepared by the Bidder shall include documents as under:

Sr. No.	Required documents
A. TECHNICAL BID	
(a)	Bidder Information Form;
(b)	Declaration abiding by the Code of Integrity and no conflict of interest for public procurement;
(c)	Bid security as specified in the Invitation to Bids;
(d)	Service support details form;
(e)	Deviation Statement Form;

(f)	Performance Statement Form;
(g)	Manufacturer's Authorization Form along with a certified copy of the Agency Agreement between the bidders and the Indian Agent;
(h)	Documentary evidence establishing that the bidder is eligible to bid and is qualified to perform the contract if its bid is accepted;
(i)	Integrity Pact, if required;
(j)	Documents establishing goods eligibility and conformity to bidding documents; indicating the Indian Customs Tariff Number (ICT & HSN No.) .
(k)	Schedule of requirements.
(l)	Self-certification that the item offered meets the minimum local content of 50% giving details of the location(s) at which the local value addition is made in case the bidder wishes to avail the benefits under the make in India policy, if applicable.
(m)	In cases of procurement for a value in excess of ₹ 10 crores, the local supplier shall be required to provide a certificate from the statutory auditor or cost auditor of the company (in the case of companies) or from a practicing cost accountant or practicing chartered accountant (in respect of suppliers other than companies) giving the percentage of local content to avail the benefits under the make in India policy, if applicable.
(n)	Documentary evidence about the status of the bidder i.e. whether MSE or not, owned by SC/ST or not and whether the MSE is owned by a women entrepreneur or not.
B. PRICE BID	
(i)	Bid form;
(ii)	Applicable Price Schedule Form;

1.11. Bid form and price schedule

1.11.1 The bidder shall complete the Bid Form and the appropriate price schedule form furnished in the bidding documents. These forms must be completed without any alterations to its format and no substitutes shall be accepted. All blank spaces shall be filled in with the information requested. The Bid Form and the appropriate Price Schedule form shall be submitted in accordance with Clause 1.18.3 of the bidding documents.

1.12. Bid Prices

1.12.1 The Bidder shall indicate on the appropriate price schedule form, the unit prices and total bid prices of the goods it proposes to supply under the contract.

1.12.2 Prices indicated on the price-schedule form shall be entered separately in the following manner:

(a)	For Goods manufactured within India	
	(i)	The price of the goods quoted Ex-works including taxes already paid.
	(ii)	GST and other taxes, if any which will be payable on the goods if the contract is awarded
	(iii)	The charges for inland transportation, insurance and other local services required for delivering the goods at the desired destination as specified in the price schedule form.
	(iv)	Wherever applicable, the cost towards the installation, commissioning, spares, extended warranty, AMC/CMC, site preparation and training including any incidental services, if any.
(b)	For Goods manufactured abroad	
	(i)	The price of the goods, quoted on FCA (named place of delivery abroad) or FOB (named port of shipment), as specified in the price schedule form.
	(ii)	The charges for insurance and transportation of the goods to the port / place of destination both by Air/Sea.
	(iii)	The agency commission charges, if any.
	(iv)	Wherever applicable, the cost towards the installation, commissioning, spares, extended warranty, AMC/CMC, site preparation and training including any incidental services, if any.

- 1.12.3 The terms FOB, FCA, CIF, CIP etc. shall be governed by the rules prescribed in the current edition of the Incoterms published by the International Chambers of Commerce, Paris.
- 1.12.4 Where **there is no mention of packing, forwarding, freight, insurance charges, taxes etc. such offer shall be rejected as incomplete.**
- 1.12.5 The price quoted shall remain fixed during the contract period and shall not vary on any account
- 1.12.6 All lots and items must be listed and priced separately in the Price Schedules. If a Price Schedule shows items listed but not priced, their prices shall be assumed to be included in the prices of other items. Lots or items not listed in the Price Schedule shall be assumed to be not included in the bid.
- 1.12.7 (a) The Purchaser is registered with Dept. of Scientific & Industrial Research, Govt. of India and concessional customs duty and GST & IGST are leviable vide notification No. 54/2002-Customs on all imports covered under Notification No.51/96-Customs dated 23.07.1996, Notification No.47/2017-Integrated Tax (Rate) and Notification No. 45/2017-Central Tax (Rate) both dated 14th November, 2017.
- (b) The Certificates is issued without any commitment by CSIR-NAL. Hence, the supplier should ensure its applicability for their own interest.
- 1.12.8 Please state specifically in your offer whether the duties and taxes are extra over the prices quoted, failing which it will be presumed that the prices are inclusive of taxes and duties and no claim would be entertained for statutory variations at a later date.
- 1.12.9 Stipulations like “GST is presently not applicable but the same will be charged if it becomes leviable later on” is not acceptable unless in such cases it is clearly stated that GST will not be charged if the same becomes applicable later on due to increase in turn over etc. If a bidder fails to comply with this requirement, his quoted price shall be loaded with the quantum of duty which is normally applicable on the item in question for the purpose of comparison with the prices of other tenderers.

Note: All payments due under the contract shall be paid after deduction of statutory levies at source (like TDS, Income-tax etc.), wherever applicable.

1.13. Bid Currencies

- 1.13.1 Prices shall be quoted in Indian Rupees for offers received for supply within India and in freely convertible foreign currency in case of offers received for supply from foreign countries i.e. domestic tenderers are to quote and accept their payment in Indian currency; Indian agents of foreign suppliers are to receive their agency commission in Indian currency; cost of imported goods & services rendered in India, which are directly imported against the contract, may be quoted in foreign currency (currencies).

1.14. Documents Establishing Bidder's Eligibility and qualifications

- 1.14.1 The bidder shall furnish, as part of its bid, documents establishing the bidders' eligibility to bid and its qualification to perform the contract if its bid is accepted.
- 1.14.2 The documentary evidence of the bidder's qualification to perform the contract if the bid is accepted shall establish to the purchaser's satisfaction that;

(a)	The bidder meets the qualification criteria listed in bidding documents if any.
(b)	Bidder who doesn't manufacture the goods it offers to supply shall submit Manufacturers' Authorization Form (MAF) using the form specified in the bidding document to demonstrate that it has been duly authorized by the manufacturer of the goods to quote and/or supply the goods
(c)	In case a bidder not doing business within India, it shall furnish the certificate to the effect that the bidder is or will be represented by an agent in India equipped and able to carry out the supply, maintenance, repair obligations etc. during the warranty and post warranty period or ensure a mechanism at place for carrying out the supply, maintenance, repair obligations etc. during the warranty and post-warranty period.

- 1.14.3 **Conditional tenders shall not be accepted.**

1.15 Documents Establishing Goods' Eligibility and Conformity to Bidding Documents

1.15.1 To establish the goods' eligibility, the documentary evidence of the goods and services eligibility shall consist of a statement on the country of origin of the goods and services offered which shall be confirmed by a certificate of origin at the time of shipment.

1.15.2 To establish the conformity of the goods and services to the specifications and schedule of requirements of the bidding document, the documentary evidence of conformity of the goods and services to the bidding documents may be in the form of literature, drawings and data, and shall consist of:

(a)	A detailed description of the essential technical and performance characteristics of the goods;
(b)	A list giving full particulars, including available sources and current prices, of spare parts, special tools, etc., necessary for the proper and continuing functioning of the goods during the warranty period following commencement of the use of the goods by the Purchaser in the Priced-bid; and
(c)	An item-by-item commentary on the Purchaser's Technical Specifications demonstrating substantial responsiveness of the goods and services to those specifications or a statement of deviations and exceptions to the provisions of the Technical Specifications.

1.15.3 For purposes of the commentary to be furnished pursuant to above, the Bidder shall note that standards for workmanship, material and equipment, designated by the Purchaser in its Technical Specifications are intended to be descriptive only and not restrictive. The Bidder may substitute these in its bid, provided that it demonstrates to the Purchaser's satisfaction that the substitutions ensure substantial equivalence to those designated in the Technical Specifications.

1.15.4 **Alternate offers/makes/models would not be considered.**

1.16. Bid Security

1.16.1 The Bidder shall furnish, as part of its bid, a bid security (BS) for an amount as specified in the Invitation for Bids. In the case of foreign bidders, the BS shall be submitted either by the principal or by the Indian agent and in the case of indigenous bidders; the BS shall be submitted by the manufacturer or their specifically authorized dealer/bidder.

1.16.2 The bid security is required to protect the Purchaser against the risk of Bidder's conduct, which would warrant the security's forfeiture.

1.16.3 The bid security shall be in Indian Rupees for offers received for supply within India and denominated in the currency of the bid or in any freely convertible foreign exchange in the case of offers received for supplies from foreign countries in equivalent Indian Rupees. The bid security shall be in one of the following forms at the bidders' option:

(a)	A Bank guarantee or stand-by Letter of Credit issued by a Nationalized/ Scheduled bank located in India or a Foreign bank with its operating branch in India in the form provided in the bidding documents or
(b)	A Banker's cheque or Account Payee demand draft in favour of the purchaser issued by any Nationalized/ Scheduled bank or
(c)	A Fixed Deposit Receipt pledged in favour of the Director, CSIR-NAL, Bengaluru.
(d)	Bid Securing Declaration

1.16.4 The bid security shall be payable promptly upon written demand by the purchaser in case the conditions listed in the ITB clause 1.16.9 are invoked.

1.16.5 The bid security should be submitted in its original form to the address mentioned below: -

Sr. CONTROLLER OF STORES & PURCHASE
CSIR-NATIONAL AEROSPACE LABORATORIES
PB NO.1779, HAL AIRPORT ROAD, KODIHALLI,
BENGALURU - 560017
KARNATAKA-INDIA

Scanned Copy of Demand Draft/Bank Guarantee towards bid security should be uploaded along with the E-bid.

- 1.16.6 The bid security of unsuccessful bidder will be discharged /returned as promptly as possible positively **within a period of 30 days after the expiration of the period of bid validity or placement of order whichever is later, without any interest.**
- 1.16.7 **The successful Bidder's bid security will be discharged upon the Bidder furnishing the performance security, without any interest.**
- 1.16.8 Bidders that are currently registered with the purchaser or registered as MSEs will continue to remain registered during the tender validity period also and are exempted from payment of EMD. In case the tenderer falls in these categories, the bidder should furnish a certified copy of its valid registration details. Except for MSEs, this exemption is valid for the trade group and monetary value of registration only. **The MSEs are provided tender document free of cost and are exempted from the payment of Bid Security provided the goods are produced and the services are rendered by them and not for any trading activities undertaken by them.** Further firms who are having Udyog Aadhar Memorandum are entitled to all benefits available for MSEs under the Public Procurement Policies for MSEs and can get registered with any of the following agencies:

(a)	District Industries Centre
(b)	Khadi and Village Industries Commission
(c)	Khadi and Village Industries Board
(d)	Coir Board
(e)	National Small Industries Corporation
(f)	Directorate of Handicraft and handloom and
(g)	Any other body specified by the Ministry of MSME

- 1.16.9 Where any aggregator has been appointed by the Ministry of MSME, themselves quote on behalf of some MSE units, such offers will be considered as offer from MSE units and all such facilities would be extended to these aggregators also.
- 1.16.10 The bid security may be forfeited:

(a)	If a Bidder withdraws or amends or modifies or impairs or derogates its bid during the period of bid validity specified by the Bidder on the Bid Form; or
(b)	In case of a successful Bidder, if the Bidder fails to furnish order acceptance within 14 days of the order or fails to sign the contract and/or fails to furnish Performance Security within 21 days from the date of contract/ order.

- 1.16.11 **Whenever the bidder chooses to submit the Bid Security in the form of Bank Guarantee, then the Bidder should advise the banker issuing the Bank Guarantee to immediately send by Registered Post (A.D.) an unstamped duplicate copy of the Guarantee directly to the Purchaser with a covering letter to compare with the original BG for the correctness, genuineness, etc.**

1.17. **Period of Validity of Bids**

- 1.17.1 Bids shall remain valid for minimum of 90 days after the date of bid opening prescribed by the Purchaser. A bid valid for a shorter period shall be rejected by the Purchaser as non-responsive.
- 1.17.2 In exceptional circumstances, the Purchaser may solicit the Bidder's consent to an extension of the period of validity. The request and the responses thereto shall be made in writing (by post, fax or e-mail). The bid security provided shall also be suitably extended failing which the bid would be summarily ignored. A Bidder may refuse the request without forfeiting its bid security. A Bidder granting the request will not be required nor permitted to modify its bid.
- 1.17.3 Bid evaluation will be based on the bid prices without taking into consideration the above corrections.

1.18. **Format and Signing of Bid**

- 1.18.1 The bids may be submitted as Single-bid or Two-bid as specified in the Invitation for Bids / NIT.
- 1.18.2 In case the bids are invited on single bid basis, then the Bidder shall submit E-bid comprising all documents listed under clause 1.9 relating to documents comprising the bid.

- 1.18.3 In case the bids are invited on two-bid system, the Bidder shall submit E-bid in two separate parts. First part shall contain Technical bid comprising all documents listed under clause relating to Documents Comprising the Bid excepting bid form and price schedule forms. The second part shall contain the Price-Bid Comprising Bid Form and Price Schedule forms.
- 1.18.4 The scanned copies of the E-bid shall be typed or written in indelible ink and shall be signed by the Bidder or a person or persons duly authorized to bind the Bidder to the Contract. **All pages of the bid, except for un-amended printed literature, shall be initialed by the person or persons signing the bid detailing his/her name and contact details.**
- 1.18.5 Any interlineations, erasures or overwriting shall be valid only if they are initialed by the persons or persons signing the bid.

D. Submission and sealing of Bids

1.19. Submission, Sealing and Marking of Bids

- 1.19.1 Bids shall be submitted online only at CPPP website <https://etenders.gov.in>
(Bids received by Manual/ Offline bids/ FAX/E-mail would not be considered for evaluation.)
- 1.19.2 The Bidder shall download the Tender Enquiry Document directly from the website <https://etenders.gov.in> and shall not tamper/modify it in any manner. In case if the same is found to be tampered/modified in any manner, Tender/Bid will be summarily rejected and EMD would be forfeited.
- 1.19.3 The complete bidding process is online. Bidders should be in possession of valid Digital Signature Certificate (DSC) of class III for online submission of bids. Prior to bidding DSC need to be registered on the website mentioned above. If the envelope is not digitally signed & encrypted the Purchaser shall not accept such open Bids for evaluation purpose and shall be treated as non-responsive and rejected.
- 1.19.4 Bidders are advised to go through “**Bidder Manual Kit**”, “**System Settings**” & “**FAQ**” links available on the login page of the e-Tender portal for guidelines, procedures & system requirements. In case of any technical difficulty, Bidders may contact the help desk numbers & email ids mentioned at the e-tender portal. Every Bidder will be required to obtain a Class-III Digital Signature (DSC) for submission of Bids.
- 1.19.5 Bidders are advised to visit CPPP website <https://etenders.gov.in> regularly to keep themselves updated, for any changes/modifications in the Tender Enquiry Document.
- 1.19.6 Intending bidders are advised to visit CPPP website <https://etenders.gov.in> regularly till closing date of submission of bid, for any corrigendum.
- 1.19.7 The Bid Security/Earnest Money Deposit shall be deposited through Bank Guarantee / Demand Draft drawn in favour of “The Director, National Aerospace Laboratories, Bengaluru”. The original Bid Security/EMD must be delivered at address mentioned in Sr.No.1 of NIT till bid submission date and time as mentioned in “Date Sheet” failing which the bid shall be summarily rejected.
- 1.19.8 Purchaser shall receive the bids online through CPPP portal only. The e-Tender portal shall automatically stop accepting bids after the scheduled date and time specified in the Tender Document. Partially submitted bids shall be treated as invalid and shall not be processed.

1.20. Deadline for Submission of Bids

- 1.20.1 Bidders are advised to upload and submit their E-bids timely within due date for submission of E-Bids in view of the electronic process so as to avoid last minute issues.
- 1.20.2 The Purchaser may, at its discretion, extend the deadline for submission of bids by amending the bid documents in accordance with Clause relating to Amendment of Bidding Documents in which case all rights and obligations of the Purchaser and Bidders previously subject to the deadline will thereafter be subject to the deadline as extended.

1.21. Late Submission of EMD

- 1.21.1 Any bid security/EMD received by the Purchaser after the due date for submission of bids prescribed by the Purchaser is liable to be rejected.
- 1.21.2 Bidders must note that the e-tender portal shall not permit uploading of bids after the scheduled time of submission.

1.22 Withdrawal, substitution and Modification of Bids

- 1.22.1 The bidder may withdraw, correct or modify his digitally signed bid after submission prior to the deadline for submission of bids, through provisions of e-tendering portal.
- 1.22.2 The bidder is not allowed to modify or withdraw bid after deadline for submission of bids.

E. Opening and Evaluation of E-Bids

1.23 Opening of E-Bids by the Purchaser

- 1.23.1 The E-bids shall be opened online by authorised officials of the Purchaser as per schedule given in Date Sheet.
- 1.23.2 In the event of the specified date of Bid opening being declared a holiday for the Purchaser, the Bids shall be opened at the appointed time and location on the next working day. In two-part bidding, the financial bid shall be opened only after technical evaluation. No separate intimation shall be sent to the bidders in this regard.
- 1.23.3 Since, E-bid is an online process; the E-bid opening or any other process may be delayed due to any technical/server issue. If any such issue arises, this will not be tantamount to process delay and CSIR-NAL will not be responsible for the same.
- 1.23.4 On opening of bids online, accepting the bid will not mean that the firm is technically or financially qualified.

1.24. Confidentiality

- 1.24.1 Information relating to the examination, evaluation, comparison, and post qualification of bids, and recommendation of contract award, shall not be disclosed to bidders or any other persons not officially concerned with such process until publication of the Contract Award.
- 1.24.2 Any effort by a Bidder to influence the Purchaser in the examination, evaluation, comparison, and post qualification of the bids or contract award decisions may result in the rejection of its Bid.

1.25. Clarification of Bids

- 1.25.1 To assist in the examination, evaluation, comparison and post qualification of the bids, the Purchaser may, at its discretion, ask the Bidder for a clarification of its bid. The request for clarification and the response shall be in writing and no change in prices or substance of the bid shall be sought, offered or permitted. However, no negotiation shall be held except with the lowest bidder, at the discretion of the purchaser. Any clarification submitted by a bidder in respect to its bid which is not in response to a request by the purchaser shall not be considered.

1.26. Preliminary Examination

- 1.26.1 The Purchaser shall examine the bids to confirm that all documents and technical documentation requested in ITB Clause 1.10 have been provided, and to determine the completeness of each document submitted.
- 1.26.2 The Purchaser shall confirm that the following documents and information have been provided in the Bid. If any of these documents or information is missing, the offer shall be rejected.

(a)	Bid Form and Price Schedule, in accordance with ITB Clause 1.10;
(b)	All the tenders received will first be scrutinized to see whether the tenders meet the basic requirements as incorporated in the tender enquiry document. The tenders, who

	do not meet the basic requirements, are to be treated as unresponsive and ignored. The following are some of the important points, for which a tender may be declared as unresponsive and to be ignored, during the initial scrutiny:
(i)	The Bid is unsigned
(ii)	The Bidder is not eligible.
(iii)	The Bid validity is shorter than the required period.
(iv)	The Bidder has quoted for goods manufactured by a different firm without the required authority letter from the proposed manufacturer.
(v)	Bidder has not agreed to give the required performance security or has not furnished the bid security.
(vi)	The goods quoted are sub-standard, not meeting the required specification, etc.
(vii)	Against the schedule of Requirement (incorporated in the tender enquiry), the bidder has not quoted for the entire requirement as specified in that schedule.
(viii)	The bidder has not agreed to some essential condition(s) incorporated in the tender enquiry.

1.27 Bidder's right to question rejection.

1.27.1 A Bidder shall have the right to be heard in case Bidder feels that a proper procurement process is not being followed and/or tender has been rejected wrongly. Only a directly affected bidder can represent in this regard as under:

i)	Only a bidder who has participated in the concerned procurement process i.e. pre-qualification, bidder registration or bidding, as the case may be, can make such representation;
ii)	In case pre-qualification bid has been evaluated before the bidding of Technical bids, an application for review in relation to the technical bid may be filed only by a bidder who has qualified in pre-qualification bid;
iii)	In case technical bid has been evaluated before the opening of the financial bid, an application for review in relation to the financial bid may be filed only by a bidder whose technical bid is found to be acceptable.
iv)	Following decisions of the purchaser in accordance with the provision of internal guidelines shall not be subject to review:
a)	Determination of the need for procurement;
b)	Selection of the mode of procurement or bidding system;
c)	Choice of selection procedure;
d)	Provisions limiting participation of bidders in the procurement process;
e)	The decision to enter into negotiations with the L1 bidder;
f)	Cancellation of the procurement process except where it is intended to subsequently re-tender the same requirements;
g)	Issues related to ambiguity in contract terms may not be taken up after a contract has been signed, all such issues should be highlighted before consummation of the contract by the vendor/contractor; and
h)	Complaints against specifications except under the premise that they are either vague or too specific so as to limit competition may be permissible.

1.27.2 In case a Bidder feels aggrieved by the decision of the purchaser, the Bidder may then send their representation in writing to the Purchaser's address as indicated in Special Conditions of Contract (SCC) **within 05 working days** from the date of communication of the purchaser intimating the rejection for reconsideration of the decision by the purchaser.

1.28 Responsiveness of Bids

1.28.1 Prior to the detailed evaluation, the purchaser will determine the substantial responsiveness of each bid to the bidding documents. For purposes of this clause, a substantive responsive bid is one, which conforms to all terms and condition of the bidding documents without material deviations, reservations or omissions. A material deviation, reservation or omission is one that:

(a)	Affects in any substantial way the scope, quality, or performance of the Goods and Related Services specified in the Contract; or
(b)	Limits in any substantial way, inconsistent with the Bidding Documents, the Purchaser's rights or the Bidder's obligations under the Contract; or
(c)	If rectified, would unfairly affect the competitive position of other bidders presenting substantially responsive bids.

- 1.28.2 The purchasers' determination of a bid's responsiveness is to be based on the contents of the bid itself without recourse to extrinsic evidence.
- 1.28.3 If a bid is not substantially responsive, it will be rejected by the Purchaser and may not subsequently be made responsive by the Bidder by correction of the material deviation, reservation or omission.
- 1.28.4 If a bidder quotes Nil Charges/consideration, the bid shall be treated as unresponsive and will not be considered.

1.29 Non-Conformity, Error and Omission

- 1.29.1 Provided that a Bid is substantially responsive, the Purchaser may waive any nonconformities or omissions in the Bid that do not constitute a material deviation.
- 1.29.2 Provided that a bid is substantially responsive, the Purchaser may request that the Bidder submit the necessary information or documentation, within a reasonable period of time, to rectify nonmaterial nonconformities or omissions in the bid related to documentation requirements. Such omission shall not be related to any aspect of the price of the Bid. Failure of the Bidder to comply with the request may result in the rejection of its Bid.
- 1.29.3 Provided that the Bid is substantially responsive, the Purchaser shall correct arithmetical errors on the following basis:

(a)	if there is a discrepancy between the unit price and the line item total that is obtained by multiplying the unit price by the quantity, the unit price shall prevail and the line item total shall be corrected, unless in the opinion of the Purchaser there is an obvious misplacement of the decimal point in the unit price, in which case the line item total as quoted shall govern and the unit price shall be corrected;
(b)	if there is an error in a total corresponding to the addition or subtraction of subtotals, the subtotals shall prevail and the total shall be corrected; and
(c)	if there is a discrepancy between words and figures, the amount in words shall prevail, unless the amount expressed in words is related to an arithmetic error, in which case the amount in figures shall prevail subject to (a) and (b) above.

- 1.29.4 Provided that a bid is substantially responsive, the purchaser may request that a bidder may confirm the correctness of arithmetic errors as done by the purchaser within a target date. In case, no reply is received then the bid submitted shall be ignored and its Bid Security may be forfeited.

1.30 Examination of Terms & Conditions, Technical Evaluation

- 1.30.1 The Purchaser shall examine the Bid to confirm that all terms and conditions specified in the GCC and the SCC have been accepted by the Bidder without any material deviation or reservation.
- 1.30.2 The Purchaser shall evaluate the technical aspects of the Bid submitted in accordance with ITB Clause 1.15, to confirm that all requirements specified in Schedule of Requirements of the Bidding Documents have been met without any material deviation or reservation.
- 1.30.3 If, after the examination of the terms and conditions and the technical evaluation, the Purchaser determines that the Bid is not substantially responsive in accordance with ITB Clause 1.28, it shall reject the Bid.

1.31 Conversion to Single Currency

- 1.31.1 To facilitate evaluation and comparison, the Purchaser will convert all quoted prices expressed in various currencies to Indian Rupees at the selling exchange rate established by any bank in India as notified in the Newspapers on the date of bid opening (techno-commercial bid in the case of two-part bidding) For this purpose, exchange rate notified in **www.xe.com** or **www.rbi.org** or any other website could also be used by the purchaser.

1.32 Evaluation and comparison of bids

- 1.32.1 The Purchaser shall evaluate each bid that has been determined, up to this stage of the evaluation, to be substantially responsive.

1.32.2 To evaluate a Bid, the Purchaser shall only use all the factors, methodologies and criteria defined below. No other criteria or methodology shall be permitted.

1.32.3 Purchase preference shall be given to all local suppliers in all procurements undertaken by the purchaser in the following manner:

(a)	Where the purchaser has restricted the eligibility of suppliers to Indian suppliers only, as per para 08 of the invitation to bid/NIT. This is applicable only for those items for which the Nodal Ministry has communicated that there is sufficient local capacity and local competition for the cost of procurement up to Rs. 50.00 lakhs.
(b)	If the tendered items are not listed by the Nodal Ministry indicating the local capacity and local competition, the following procedure of evaluation shall be followed, irrespective of value:
(i)	Among all qualified bids, the lowest bid will be termed as L1. If L1 is from a local supplier, the contract for full quantity will be awarded to L1.
(ii)	If L1 bid is not from a local supplier, 50% of the order quantity shall be awarded to L1. Thereafter, the lowest bidder among the local suppliers, will be invited to match the L1 price for the remaining 50% quantity, subject to the local supplier 's quoted price which should fall within the margin of purchase preference of 20%. The contract for that quantity shall be awarded to such local supplier, who matches the L1 price. In case such lowest eligible local supplier fails to match the L1 price or accepts less than the offered quantity, the next higher local supplier within the margin of purchase preference shall be invited to match the L1 price for the remaining quantity and so on. The contract shall be awarded accordingly. In case some quantity is still left uncovered on the part of local suppliers, the balance quantity may also be ordered to the L1 bidder.
(c)	If the tendered item is not divisible, the following procedure of evaluation shall be followed:
(i)	Among all qualified bids, the lowest bid will be termed as L1. If L1 is from a local supplier, the contract will be awarded to L1.
(ii)	If L1 is not from a local supplier, the lowest bidder among the local suppliers will be invited to match the L1 price, subject to local supplier's quoted price falling within the margin of purchase preference of 20%. Accordingly, the contract shall be awarded to the local supplier matching the L1 price.
(iii)	In case such lowest eligible local supplier fails to match the L1 price, the local supplier with the next higher bid within the margin of purchase preference shall be invited to match the L1 price. This may be repeated until all the local suppliers are given an opportunity to match the L1 price. The contract shall be awarded accordingly. In case none of the local suppliers within the margin of purchase preference match the L1 price, the contract may be awarded to the L1 bidder.

1.32.4 Further, in tender, where the items are divisible, the participating Micro and Small Enterprises (MSE) quoting price within price band of L1+15 (fifteen) per cent shall also be allowed to supply a portion of requirement by bringing down their price to L1 price in a situation where L1 price is from someone other than a MSE and such MSE shall be allowed to supply up to 25 (twenty-five) per cent of total tendered value. The 25 (twenty-five) per cent quantity is to be distributed proportionately among these bidders, in case there are more than one MSMES within such price band.

1.32.5 Within this 25% (Twenty-five Percent) quantity, a purchase preference of 25 (twenty-five) per cent out of 25 (twenty-five) per cent is reserved for MSEs owned by Scheduled Caste (SC)/Scheduled Tribe (ST) entrepreneurs (if they participate in the tender process and match the L1 price). Further, out of the total annual procurement from the MSEs, (3%) three percent from within the 25% target shall be earmarked for procurement from MSEs owned by women. Provided that, in the event of failure of such SC/ST MSE to participate in tender process or meet tender requirements and L1 price, four per cent sub-target shall be met from other MSE.

1.32.6 In case the items are not divisible, then the MSE quoting price within price band L1 + 15% may be awarded for full/complete supply of total tendered quantity to MSE, considering the spirit of the policy for enhancing the Government procurement from MSEs.

1.32.7 The bids shall be evaluated on the basis of final landing cost which shall be arrived as under:

(a) **For Goods manufactured in India**

i)	The price of the goods quoted ex-works including all taxes already paid.
ii)	GST and other taxes, if any which will be payable on the goods if the contract is awarded.
iii)	Charges for inland transportation, insurance and other local services required for delivering the goods at the desired destination.
iv)	Wherever applicable, the cost towards the installation, commissioning, spares, extended warranty, AMC/CMC, site preparation and training including any incidental services, if any.

(b) **For Goods manufactured abroad**

i)	The price of the goods, quoted on FCA (named place of delivery abroad) or FOB (named port of shipment), as specified in the bidding document.
ii)	The charges for insurance and transportation of the goods to the port/place of destination.
iii)	The agency commission etc., if any.
iv)	Wherever applicable, the cost towards the installation, commissioning, spares, extended warranty, AMC/CMC, site preparation and training including any incidental services, if any.

1.32.8 The comparison between the indigenous and the foreign offers shall be made on FOR destination basis and CIF/CIP basis respectively. However, the CIF/CIP prices quoted by any foreign bidder shall be loaded further as under:

(a)	Towards customs duty and other statutory levies – as per applicable rates.
(b)	Towards custom clearance, inland transportation etc. - 2% of the CIF/CIP value.

The bidder should give a clear cut breakup of EXW, FOB/FCA, CIF/CIP prices to facilitate proper comparison with the purchaser reserving the right to order on either basis, failing which the bid would be summarily ignored.

1.32.9 Orders for imported stores need not necessarily be on FOB/FCA basis rather it can be on the basis of any of the incoterm specified in ICC Incoterms 2010 as may be amended from time to time by the ICC or any other designated authority and favourable to the purchaser.

1.32.10 **Wherever the price quoted on FOB/FCA and CIF/CIP basis are the same, the Contract would be made on CIF / CIP basis only.**

1.32.11 The GCC and the SCC shall specify the mode of transport i.e., whether by Air/Sea/Road/Rail.

1.32.12 There is **no provision to purchase optional items**. The specifications embodied in the tender documents would be the basis of evaluating the responsiveness of bids received.

1.32.13 The Purchaser shall compare all substantially responsive bids to determine the lowest valued bid, in accordance with ITB Clause 1.32.

1.32.14 Where there is no mention of packing, forwarding, freight, insurance charges, taxes etc. such offers shall be rejected as incomplete.

1.33 [Contacting the Purchaser](#)

1.33.1 Subject to ITB Clause 1.25, **no Bidder shall contact the Purchaser on any matter relating to its bid, from the time of the bid opening to the time the Contract is awarded.**

1.33.2 Any effort by a Bidder to influence the Purchaser in its decisions on bid evaluation, bid comparison or contract award may result in rejection of the Bidder's bid.

1.34 [Post qualification](#)

1.34.1 In the absence of pre-qualification, the Purchaser will determine to its satisfaction whether the Bidder that is selected as having submitted the lowest evaluated responsive bid is qualified to perform the contract satisfactorily, in accordance with the criteria listed in ITB Clause 1.14.

- 1.34.2 The determination will take into account the eligibility criteria listed in the bidding documents and will be based upon an examination of the documentary evidence of the Bidder's qualifications submitted by the Bidder, as well as such other information as the Purchaser deems necessary and appropriate.
- 1.34.3 An affirmative determination will be a prerequisite for award of the contract to the Bidder. A negative determination will result in rejection of the Bidder's bid.

E. AWARD OF CONTRACT

1.35 Negotiations

- 1.35.1 Normally, there shall not be any negotiation. Negotiations, if at all, shall be an exception and only in the case of items with limited source of supply. Negotiations shall be held with the lowest evaluated responsive bidder. Counter offers tantamount to negotiations and shall be treated at par with negotiations in the case of one time purchases.

1.36 Award Criteria

- 1.36.1 Subject to ITB Clause 1.39, the Purchaser will award the contract to the successful Bidder whose bid has been determined to be substantially responsive and has been determined to be the lowest evaluated bid, provided further that the Bidder is determined to be qualified to perform the contract satisfactorily. The details of the award would be hosted on the website of the Purchaser and CPPP website <https://etenders.gov.in>.

1.37 Purchaser's right to vary Quantities at Time of Award

- 1.37.1 The Purchaser reserves the right at the time of Contract award to increase or decrease the quantity of goods and services originally specified in the Schedule of Requirements to the extent of 25% without any change in unit price or other terms and conditions.

1.38 Option Clause

- 1.38.1 The Purchaser reserves the right to increase or decrease the quantity of the required goods up to 25% (Twenty-Five) per cent at any time, till final delivery date (or the extended delivery date of the contract), by giving reasonable notice even though the quantity ordered initially has been supplied in full before the last date of the delivery period (or the extended delivery period)

1.39 Purchaser's right to accept Any Bid and to reject any or All Bids

- 1.39.1 The Purchaser reserves the right to accept or reject any bid, and to annul the bidding process and reject all bids at any time prior to award of Contract, without thereby incurring any liability to the affected Bidder or Bidders.

1.40 Notification of Award

- 1.40.1 **Prior to the expiration of the period of bid validity**, the Purchaser will notify the successful bidder in writing by registered letter or by cable or telex or fax or e mail that the bid has been accepted and a separate purchase order shall follow through post.
- 1.40.2 Until a formal contract is prepared and executed, the notification of award should constitute a binding contract.
- 1.40.3 Upon the successful Bidder's **furnishing of the signed Contract Form** and performance security pursuant to ITB Clause 1.43, the Purchaser will promptly notify each unsuccessful Bidder and will discharge its bid security.

1.41 Signing of Contract

- 1.41.1 Promptly after notification, the Purchaser shall send the successful Bidder the Agreement/Purchase Order.
- 1.41.2 Within twenty-one (21) days of date of the Purchase Order, the successful Bidder shall sign, date, and return it to the Purchaser.

1.42 Order Acceptance

- 1.42.1 The successful bidder should submit Order acceptance within 14 days from the date of issue of order/signing of contract, failing which it shall be presumed that the Bidder is not interested and the bid security is liable to be forfeited pursuant to clause 1.16.9 of ITB.
- 1.42.2 The order confirmation must be received within 14 days. However, the Purchaser has the powers to extend the time frame for submission of order confirmation beyond the original date. Even after extension of time, if the order confirmation is not received, the contract is liable to be cancelled provided that the purchaser, on being satisfied that it is not a case of cartelization and the integrity of the procurement process has been maintained, may, for cogent reasons, offer the next successful bidder an opportunity to match the financial bid of the first successful bidder, and if the offer is accepted, award the contract to the next successful bidder at the price bid of the first successful bidder.

1.43 Performance Security

- 1.43.1 Within 21 days of receipt of the notification of award/PO, the Supplier shall furnish performance security (PS) in the amount specified in SCC, valid till 60 days after the warranty period.
- 1.43.2 The proceeds of the performance security shall be payable to the Purchaser as compensation for any loss resulting from the Supplier's failure to complete its obligations under the Contract.
- 1.43.3 The Performance Security shall be denominated in Indian Rupees for the offers received for supplies within India and denominated in the currency of the contract in the case of offers received for supply from foreign countries or in equivalent Indian rupees in case the performance security is submitted by the Indian Agent.
- 1.43.4 In the case of imports, the PS may be submitted either by the principal or by the Indian agent and, in the case of purchases from indigenous sources, the PS may be submitted by either the manufacturer or their authorized dealer/bidder.
- 1.43.5 The Performance security shall be in one of the following forms:

(a)	A Bank guarantee or stand-by Letter of Credit issued by a Nationalized/ Scheduled bank located in India or a Foreign bank with its operating branch in India in the form provided in the bidding documents or
(b)	A Banker's cheque or Account Payee demand draft in favour of the purchaser issued by any Nationalized/ Scheduled bank or
(c)	A Fixed Deposit Receipt pledged in favour of the Director, CSIR-NAL, Bengaluru.

- 1.43.6 The performance security will be discharged by the Purchaser and returned to the Supplier not later than 60 days following the date of completion of the Supplier's performance obligations, including any warranty obligations, unless specified otherwise in SCC, without levy of any interest.
- 1.43.7 In the event of any contract amendment, the supplier shall, within 21 days of receipt of such amendment, furnish the amendment to the performance security, rendering the same valid for the duration of the contract, as amended for further period of 60 days thereafter.
- 1.43.8 The performance security must be received within 21 days. However, the Purchaser has the powers to extend the time frame for submission of Performance Security (PS). Even after extension of time, if the PS is not received, the contract is liable to be cancelled provided that the purchaser, on being satisfied that it is not a case of cartelization and the integrity of the procurement process has been maintained, may, for cogent reasons, offer the next successful bidder an opportunity to match the financial bid of the first successful bidder, and if the offer is accepted, award the contract to the next successful bidder at the price bid of the first successful bidder.
- 1.43.9 Whenever, the bidder chooses to submit the Performance Security in the form of Bank Guarantee, then the Bidder should advise the banker issuing the Bank Guarantee to immediately send by Registered Post (A.D.) an unstamped duplicate copy of the Guarantee directly to the Purchaser with a covering letter to compare with the original BG for the correctness, genuineness, etc.**

1.44. Pre-bid Conference (PBC)

- 1.44.1 A Pre-bid Conference shall be held as indicated in invitation to bid, if any. All prospective bidders are requested to kindly attend the Pre-bid Conference. In order to facilitate the purchaser the proper conduct of the Pre-bid Conference, all prospective bidders are requested to kindly submit

their queries (with envelope bearing Tender No. and Date on top and marked “Queries for Pre-bid Conference”) so as to reach the purchaser as indicated in invitation to bid. The purchaser shall answer the queries during the pre-bid conference, which would become a part of the proceedings of the Pre-bid Conference. The proceeding of the Pre Bid Conference would be hosted on the website of the purchaser. Before formulating and submitting their bids, all prospective bidders are advised to surf through the purchaser’s website after the Pre-bid Conference, in order to enable them take cognizance of the revised tender conditions.

1.45 Integrity Pact

1.45.1 Integrity Pact binds both buyers and sellers to ethical conduct and transparency in all activities from pre-selection of bidders, bidding and contracting, implementation, completion and operation related to the contract.

1.45.2 The Integrity pact essentially envisages an agreement between the prospective vendors/bidders and the buyer, committing the persons/officials of both sides, not to resort to any corrupt practices in any aspect/stage of the contract. Only those vendors/bidders, who commit themselves to such a Pact with the buyer, would be considered competent to participate in the bidding process. In other words, entering into this Pact would be a preliminary qualification. The essential ingredients of the Pact include:

(i)	Promise on the part of the Purchaser to treat all bidders with equity and reason and not to seek or accept any benefit, which is not legally available;
(ii)	Promise on the part of bidders not to offer any benefit to the employees of the Purchaser not available legally and also not to commit any offence under Prevention of Corruption Act, 1988 or Indian Penal Code 1860;
(iii)	Promise on the part of bidders not to enter into any undisclosed agreement or understanding with other bidders with respect to prices, specifications, certifications, subsidiary contracts; etc.
(iv)	Undertaking (as part of Fall Clause) by the bidders that they have not and will not sell the same material/equipment at prices lower than the bid price;
(v)	Foreign bidders to disclose the name and address of agents and representatives in India and Indian Bidders to disclose their foreign principals or associates;
(vi)	Bidders to disclose the payments to be made by them to agents/brokers or any other intermediary;
(vii)	Bidders to disclose any past transgressions committed over the specified period with any other company in India or Abroad that may impinge on the anti-corruption principle;
(viii)	Integrity Pact lays down the punitive actions for any violation.

1.45.3 Each page of such Integrity pact proforma would be duly signed by Purchaser’s competent signatory. All pages of the Integrity Pact are to be returned by the bidder (along with the technical bid) duly signed by the same signatory who signed the bid, i.e. who is duly authorized to sign the bid and to make binding commitments on behalf of his company. Any bid not accompanied by Integrity Pact duly signed by the bidder shall be considered to be a non-responsive bid and shall be rejected straightway.

1.45.4 The SCC shall specify whether there is a need to enter into a separate Integrity pact or not.

1.45.5 The Integrity Pact would be effective from the date of invitation of bids till complete execution of the contract.

1.45.6 The names and contact details of the Independent External Monitors (IEM) on the event of the need of IP is as detailed in the SCC.

1.45.7 The modal format of IP is at Chapter-7.

1.45.8 As a first option, dispute resolution is available through panel of IEMs’ apart from arbitration clause. However, the fees / exemptions on the said account shall be equally shared by the parties.

1.46 Assistance to Bidders:

1.46.1 Any queries relating to the Tender Enquiry Document and the terms and conditions contained

therein should be addressed to the Tender Inviting Authority for a tender or the relevant contact person indicated in the NIT.

- 1.46.2 Any queries relating to the process of online bid submission or queries relating to CPP Portal in general may be directed to the 24x7 CPP Portal Helpdesk.

CHAPTER 2
CONDITIONS OF CONTRACT
A GENERAL CONDITIONS OF CONTRACT (GCC)

Clause No.	Contents
2.1	Definitions
2.2	Contract Documents
2.3	Code of Integrity
2.4	Joint Venture, Consortium or Association
2.5	Scope of Supply
2.6	Suppliers' Responsibilities
2.7	Contract price
2.8	Copy Right
2.9	Application
2.10	Standards
2.11	Use of Contract Documents and Information
2.12	Patent Indemnity
2.13	Performance Security
2.14	Inspections and Tests
2.15	Packing
2.16	Delivery and Documents
2.17	Insurance
2.18	Transportation
2.19	Incidental Services
2.20	Spare Parts
2.21	Warranty
2.22	Terms of Payment
2.23	Change Orders and Contract Amendments
2.24	Assignment
2.25	Subcontracts
2.26	Extension of time
2.27	Liquidated Damages
2.28	Termination for Default
2.29	Force Majeure
2.30	Termination for insolvency
2.31	Termination for Convenience
2.32	Settlement of Disputes
2.33	Governing Language
2.34	Applicable Law
2.35	Notice
2.36	Taxes and Duties
2.37	Right to use Defective Goods
2.38	Protection against Damage
2.39	Site preparation and installation
2.40	Import and Export Licenses
2.41	Risk Purchase Clause
2.42	Option Clause
2.43	Integrity Pact
2.44	Order Acceptance

Note: The General Conditions of Contract shall form the part of Purchase Order / Contract.

GENERAL CONDITIONS OF CONTRACT (GCC)

2.1 Definitions

2.1.1 The following words and expressions shall have the meanings hereby assigned to them:

Sr.	Words / Expressions	Meaning
(a)	Contract	The Contract Agreement entered into between the Purchaser and the Supplier, together with the Contract Documents referred to therein, including all attachments, appendices, and all documents incorporated by reference therein.
(b)	Contract Documents	The documents listed in the Contract Agreement, including any amendments thereto.
(c)	Contract Price	The price payable to the Bidder as specified in the Contract Agreement, subject to such additions and adjustments thereto or deductions there from, as may be made pursuant to the Contract.
(d)	Day	Calendar day
(e)	Completion	The fulfilment of the Related Services by the Supplier in accordance with the terms and conditions set forth in the Contract.
(f)	GCC	The General Conditions of Contract.
(g)	Goods	All of the commodities, raw material, machinery and equipment, and/or other materials that the Supplier is required to supply to the Purchaser under the Contract
(h)	Services	The services incidental to the supply of the goods, such as transportation, insurance, installation, training and initial maintenance and other such obligations of the Supplier under the Contract.
(i)	SCC	The Special Conditions of Contract.
(j)	Subcontractor	Any natural person, private or government entity, or a combination of the above, to which any part of the Goods to be supplied or execution of any part of the Related Services is subcontracted by the Supplier.
(k)	Bidder	The natural Person, Private or Government entity, or a combination of the above, whose bid to perform the Contract has been accepted by the Purchaser and is named as such in the Contract Agreement.
(l)	Council	The Council of Scientific & Industrial Research (CSIR), registered under the Societies Registration Act, 1860 of the Government of India having its registered office at 2, Rafi Marg, New Delhi-110001, India.
(m)	Purchaser	Any of the constituent Laboratory/Institute of the Council situated at any designated place in India as specified in SCC
(n)	The final destination	The place named in the SCC.

2.2 Contract Documents

2.2.1 Subject to the order of precedence set forth in the Contract Agreement, all documents forming the Contract (and all parts thereof) are intended to be correlative, complementary, and mutually explanatory. The Contract Agreement shall be read as a whole.

2.3 Code of Integrity

2.3.1 Without prejudice to and in addition to the rights of the Purchaser to other penal provisions as per the bid documents or contract, if the Purchaser comes to a conclusion that a (prospective) bidder/supplier, directly or through an agent, has violated this code of integrity in competing for the contract or in executing a contract, the Purchaser may take appropriate measures including one or more of the following:

a)	Cancellation of the relevant contract and recovery of compensation for loss incurred by the purchaser;
b)	Forfeiture or encashment of any other security or bond relating to the procurement;
c)	Recovery of payments including advance payments, if any, made by the Purchaser along with interest thereon at the prevailing rate.

d)	Provisions in addition to above:	
	1)	Removal from the list of registered suppliers and banning/debarment of the bidder from participation in future procurements of the purchaser for a period not less than one year;
	2)	In case of anti-competitive practices, information for further processing may be filed under a signature of the Joint Secretary level officer, with the Competition Commission of India;
	3)	Initiation of suitable disciplinary or criminal proceedings against any individual or staff found responsible

2.4 Joint Venture, Consortium or Association

2.4.1 If the Supplier is a joint venture, consortium, or association, all of the parties shall be jointly and severally liable to the Purchaser for the fulfilment of the provisions of the Contract and shall designate one party to act as a leader with authority to bind the joint venture, consortium, or association. The composition or the constitution of the joint venture, consortium, or association shall not be altered without the prior consent of the Purchaser.

2.5 Scope of Supply

2.5.1 The Goods and Related Services to be supplied shall be as specified in Chapter 4 i.e. Specifications and allied technical details.

2.6 Suppliers' Responsibilities

2.6.1 The Supplier shall supply all the Goods and Related Services included in the Scope of Supply in accordance with Scope of Supply Clause of the GCC, and the Delivery and Completion Schedule, as per GCC Clause relating to delivery and document.

2.7 Contract price

2.7.1 Prices charged by the Supplier for the Goods supplied and the Related Services performed under the Contract shall not vary from the prices quoted by the Supplier in its bid.

2.8 Copy Right

2.8.1 The copyright in all drawings, documents, and other materials containing data and information furnished to the Purchaser by the Supplier herein shall remain vested in the Supplier, or, if they are furnished to the Purchaser directly or through the Supplier by any third party, including suppliers of materials, the copyright in such materials shall remain vested in such third party.

2.9 Application

2.9.1 These General Conditions shall apply to the extent that they are not superseded by provisions in other parts of the Contract.

2.10 Standards

2.10.1 The Goods supplied and services rendered under this Contract shall conform to the standards mentioned in the Technical Specifications, and, when no applicable standard is mentioned, to the authoritative standard appropriate to the Goods' country of origin and such standards shall be the latest issued by the concerned institution.

2.11 Use of Contract Documents and Information

2.11.1 The Supplier shall not, without the Purchaser's prior written consent, disclose the Contract, or any provision thereof, or any specification, plan, drawing, pattern, sample or information furnished by or on behalf of the Purchaser in connection therewith, to any person other than a person employed by the Supplier in performance of the Contract. Disclosure to any such employed person shall be made in confidence and shall extend only so far, as may be necessary for purposes of such performance.

- 2.11.2 The Supplier shall not, without the Purchaser's prior written consent, make use of any document or information enumerated above except for purposes of performing the Contract.
- 2.11.3 Any document, other than the Contract itself, enumerated above shall remain the property of the Purchaser and shall be returned (in all copies) to the Purchaser on completion of the Supplier's performance under the Contract if so required by the Purchaser.

2.12 Patent Indemnity

- 2.12.1 The Supplier shall, subject to the Purchaser's compliance with GCC Sub-Clause 2.12.2 Indemnify and hold harmless the Purchaser and its employees and officers from and against any and all suits, actions or administrative proceedings, claims, demands, losses, damages, costs, and expenses of any nature, including attorney's fees and expenses, which the Purchaser may suffer as a result of any infringement or alleged infringement of any patent, utility model, registered design, trademark, copyright, or other intellectual property right registered or otherwise existing at the date of the Contract by reason of:

(a)	the installation of the Goods by the Supplier or the use of the Goods in India; and
(b)	the sale in any country of the products produced by the Goods

- 2.12.2 If any proceedings are brought or any claim is made against the Purchaser, the Purchaser shall promptly give the Supplier a notice thereof, and the Supplier may at its own expense and in the Purchaser's name conduct such proceedings or claim and any negotiations for the settlement of any such proceedings or claim.

2.13 Performance Security

- 2.13.1 Within 21 days of receipt of the notification of award/PO, the Supplier shall furnish performance security in the amount specified in SCC, valid till 60 days after the warranty period.
- 2.13.2 The proceeds of the performance security shall be payable to the Purchaser as compensation for any loss resulting from the Supplier's failure to complete its obligations under the Contract.
- 2.13.3 The Performance Security shall be denominated in Indian Rupees for the offers received for supplies within India and denominated in the currency of the contract in the case of offers received for supply from foreign countries or in equivalent Indian Rupees in case the Performance Security is submitted by the Indian Agent.
- 2.13.4 In the case of imports, the PS may be submitted either by the principal or by the Indian agent and, in the case of purchases from indigenous sources, the PS may be submitted by either the manufacturer or their authorized dealer/bidder.
- 2.13.5 The Performance security shall be in one of the following forms:

(a)	A Bank guarantee or stand-by Letter of Credit issued by a Nationalized/ Scheduled bank located in India or a Foreign bank with its operating branch in India in the form provided in the bidding documents or
(b)	A Banker's cheque or Account Payee demand draft in favour of the purchaser issued by any Nationalized/ Scheduled bank or
©	A Fixed Deposit Receipt pledged in favour of the Director, CSIR-NAL, Bengaluru.

- 2.13.6 The performance security will be discharged by the Purchaser and returned to the Supplier not later than 60 days following the date of completion of the Supplier's performance obligations, including any warranty obligations, unless specified otherwise in SCC, without levy of any interest.
- 2.13.7 In the event of any contract amendment, the supplier shall, within 21 days of receipt of such amendment, furnish the amendment to the performance security, rendering the same valid for the duration of the contract, as amended for further period of 60 days thereafter.
- 2.13.8 The order confirmation must be received within 14 days. However, the Purchaser has the powers to extend the time frame for submission of order confirmation and submission of Performance Security (PS). Even after extension of time, if the order confirmation /PS are not received, the

contract shall be cancelled provided that the purchaser, on being satisfied that it is not a case of cartelization and the integrity of the procurement process has been maintained, may, for cogent reasons, offer the next successful bidder an opportunity to match the financial bid of the first successful bidder, and if the offer is accepted, award the contract to the next successful bidder at the price bid of the first successful bidder.

- 2.13.9 Whenever, the bidder chooses to submit the Performance Security in the form of Bank Guarantee, then Bidder should advise the banker issuing the Bank Guarantee to immediately send by Registered Post (A.D.) an unstamped duplicate copy of the Guarantee directly to the Purchaser with a covering letter to compare with the original BG for the correctness, genuineness, etc.**

2.14 Inspections and Tests

- 2.14.1 The inspections & test, training required would be as detailed in Chapter-4 of the Bidding Document relating to Specification and Allied Technical details.

2.15 Packing

- 2.15.1 The Supplier shall provide such packing of the Goods as is required to prevent their damage or deterioration during transit to their final destination as indicated in the Contract. The packing shall be sufficient to withstand, without limitation, rough handling during transit and exposure to extreme temperatures, salt and precipitation during transit and open storage. Packing case size and weights shall take into consideration, where appropriate, the remoteness of the Goods' final destination and the absence of heavy handling facilities at all points in transit.

- 2.15.2 The packing, marking and documentation within and outside the packages shall comply strictly with such special requirements as shall be provided for in the Contract including additional requirements are as given below or /and as specified in SCC and in any subsequent instructions ordered by the Purchaser:

The marking and documentation within and outside the packages shall be:

(a)	Each package should have a packing list within it detailing the part No(s), description, quantity etc.
(b)	Outside each package, the contract No., the name and address of the purchaser and the final destination should be indicated on all sides and top.
(c)	Each package should be marked as 1/x, 2/x, 3/x.....x/x, where "x" is the total No. of packages contained in the consignment
(d)	All the sides and top of each package should carry an Appropriate indication/ label/ stickers indicating the precautions to be taken while handling/storage.

2.16 Delivery and Documents

- 2.16.1 Delivery of the Goods and completion and related services shall be made by the supplier in accordance with the terms specified by the Purchaser in the contract. The details of shipping and/or other documents are given below or/and to be furnished by the supplier are specified in SCC.

Details of Shipping and other Documents to be furnished by the Bidder are :	
A)	For goods manufactured or supplied within India
	Within 24 hours of dispatch, the Supplier shall notify the purchaser the complete details of dispatch and also supply following documents by registered post / speed post and copies thereof by FAX/email
(a)	Two copies of Supplier's Invoice indicating, inter-alia description and specification of the goods, quantity, unit price, total value
(b)	Packing list
(c)	Certificate of country of origin
(d)	Insurance certificate, if required under the contract
(e)	Railway receipt/Consignment note
(f)	Manufacturer's warrantee certificate and in-house inspection certificate, if any
(g)	Inspection certificate issued by purchaser's inspector, if any
(h)	Any other document(s) as and when required in terms of the contract
NOTE:	

1	The nomenclature used for the item description in the invoice(s), packing list(s) and the delivery note(s) etc. should be identical to that used in the contract. The dispatch particulars including the name of the transporter should also be mentioned in the Invoice(s).
2	The above documents should be received by the Purchaser before arrival of the Goods and, if not received, the Bidder will be responsible for any consequent expenses.
B)	For goods manufactured or supplied from abroad
	Within 24 hours of dispatch, the Supplier shall notify the purchaser the complete details of dispatch and also supply following documents by Registered Post / Courier and copies thereof by FAX/Email.
(a)	Two copies of Bidder's Invoice giving full details of the goods including quantity, value, etc.
(b)	Packing list
(c)	Certificate of country of origin
(d)	Manufacturer's guarantee and Inspection certificate, if any
(e)	Inspection certificate issued by the Purchaser's Inspector, if any
(f)	Insurance Certificate, if required under the contract
(g)	Name of the Vessel / Carrier
(h)	Bill of Lading / Airway Bill
(i)	Port of Loading
(j)	Date of Shipment
(k)	Port of Discharge & expected date of arrival of goods
(l)	Any other document(s) as and when required in terms of the contract
NOTE:	
1	The nomenclature used for the item description in the invoice(s), packing list(s) and the delivery note(s) etc. should be identical to that used in the contract. The dispatch particulars including the name of the transporter should also be mentioned in the Invoice(s).
2	The above documents should be received by the Purchaser before arrival of the Goods and, if not received, the Bidder will be responsible for any consequent expenses.
3	The clearing of the consignment at Bengaluru Airport shall be done by our authorized Custom House Agents (CHA). The corresponding shipping documents may be forwarded to them accordingly. It is advised to give us and our CHA, a pre-alert before the consignment is dispatched. If there is delay in clearing of the consignment for <u>not</u> giving timely pre-alert then demurrage (Ware house charges), if applicable has to be refunded to us.

2.16.2 The terms FOB, FCA, CIF, CIP, etc. shall be governed by the rules prescribed in the current edition of the Inco terms published by the International Chambers of Commerce, Paris.

2.16.3 The mode of transportation shall be as specified in SCC. In case the purchaser elects to have the transportation done through Air, then air lifting needs to be done through Air India only. In case Air India does not operate in the Airport of dispatch, then the bidder is free to engage the services of any other Airlines.

2.16.4 High-sea sales delivery-term is not acceptable.

2.17 Insurance

2.17.1 Should the purchaser elect to buy on CIF/CIP basis, the Goods supplied under the Contract shall be fully insured against any loss or damage incidental to manufacture or acquisition, transportation, storage and delivery in the manner specified in SCC.

2.17.2 Where delivery of the goods is required by the purchaser on CIF or CIP basis the supplier shall arrange and pay for Cargo Insurance, naming the purchaser as beneficiary and initiate & pursue claims till settlement, on the event of any loss or damage.

2.17.3 Where delivery is on FOB or FCA basis, insurance would be the responsibility of the purchaser.

2.17.4 With a view to ensure that claims on insurance companies, if any, are lodged in time, the bidders and /or the Indian agent shall be responsible for follow up with their principals for ascertaining the dispatch details and informing the same to the Purchaser and he shall also liaise with the Purchaser to ascertain the arrival of the consignment after clearance so that immediately

thereafter in his presence the consignment could be opened and the insurance claim be lodged, if required, without any loss of time. Any delay on the part of the bidder/Indian Agent would be viewed seriously and he shall be directly responsible for any loss sustained by the purchaser on the event of the delay.

2.18 Transportation

- 2.18.1 Where the Supplier is required under the Contract to deliver the Goods FOB, transport of the Goods, up to and including the point of putting the Goods on board the vessel at the specified port of loading, shall be arranged and paid for by the Supplier, and the cost thereof shall be included in the Contract price. Where the Supplier is required under the Contract to deliver the Goods FCA, transport of the Goods and delivery into the custody of the carrier at the place named by the Purchaser or other agreed point shall be arranged and paid for by the Supplier, and the cost thereof shall be included in the Contract Price.
- 2.18.2 Where the Supplier is required under the Contract to deliver the Goods CIF or CIP, transport of the Goods to the port of destination or such other named place of destination in the Purchaser's country, as shall be specified in the Contract, shall be arranged and paid for by the Supplier, and the cost thereof shall be included in the Contract Price.
- 2.18.3 In the case of supplies from within India, where the Supplier is required under the Contract to transport the Goods to a specified destination in India, defined as the Final Destination, transport to such destination, including insurance and storage, as specified in the Contract, shall be arranged by the Supplier, and the related costs shall be included in the Contract Price.

2.19 Incidental Services

- 2.19.1 The supplier may be required to provide any or all of the services, including training, if any, specified in chapter 4.

2.20 Spare Parts

- 2.20.1 The Supplier shall be required to provide any or all of the following materials, notifications, and information pertaining to spare parts manufactured or distributed by the Supplier:

(a)	Such spare parts as the Purchaser may elect to purchase from the Supplier, providing that this election shall not relieve the Supplier of any warranty obligations under the Contract; and
(b)	In the event of termination of production of the spare parts:
(i)	Advance notification to the Purchaser of the pending termination, in sufficient time to permit the Purchaser to procure needed requirements; and
(ii)	Following such termination, furnishing at no cost to the Purchaser, the blueprints, drawings and specifications of the spare parts, if requested.

2.21 Warranty

- 2.21.1 The Supplier warrants that all the Goods are new, unused, and of the most recent or current models, and that they incorporate all recent improvements in design and materials, unless provided otherwise in the Contract.
- 2.21.2 The Supplier further warrants that the Goods shall be free from defects arising from any act or omission of the Supplier or arising from design, materials, and workmanship, under normal use in the conditions prevailing in India.
- 2.21.3 Unless otherwise specified in the SCC, the warranty shall remain valid for Twelve (12) months after the Goods, or any portion thereof as the case may be, have been delivered to and accepted at the final destination indicated in the SCC, or for Eighteen (18) months after the date of shipment from the port or place of loading in the country of origin, whichever period concludes earlier.
- 2.21.4 The Purchaser shall give notice to the Supplier stating the nature of any such defects together with all available evidence thereof, promptly following the discovery thereof. The Purchaser shall afford all reasonable opportunity for the Supplier to inspect such defects.
- 2.21.5 Upon receipt of such notice, the Supplier shall, within a reasonable period of time, expeditiously repair or replace the defective Goods or parts thereof, at no cost to the Purchaser.

- 2.21.6 If having been notified, the Supplier fails to remedy the defect within a reasonable period of time; the Purchaser may proceed to take within a reasonable period such remedial action as may be necessary, at the Supplier's risk and expense and without prejudice to any other rights which the Purchaser may have against the Supplier under the Contract.
- 2.21.7 Goods requiring warranty replacements must be replaced on free of cost basis to the purchaser.

2.22 Terms of Payment

- 2.22.1 The method and conditions of payment to be made to the Supplier under this Contract shall be as specified in the SCC.
- 2.22.2 The Supplier's request(s) for payment shall be made to the Purchaser in writing, accompanied by an invoice describing, as appropriate, the Goods delivered and the Services performed, and by documents, submitted pursuant to Delivery and document Clause of the GCC and upon fulfilment of other obligations stipulated in the contract.
- 2.22.3 Payments shall be made promptly by the Purchaser but in no case later than thirty (30) days after submission of the invoice or claim by the Supplier. While claiming the payment, the supplier should certify in the bill/invoice that the payment being claimed strictly in terms of the contract and all obligations on the part of the supplier for claiming the payment have been fulfilled as required under the contract.
- 2.22.4 Payment shall be made in currency as indicated in the contract.

2.23 Change Orders and Contract Amendments

- 2.23.1 The Purchaser may at any time, by written order given to the Supplier pursuant to Clause on Notices of the GCC make changes within the general scope of the Contract in any one or more of the following:

(a)	Increase or decrease in the quantity required, exercise of quantity opinion clause;
(b)	Changes in schedule of deliveries and terms of delivery;
(c)	The changes in inspection arrangements;
(d)	Changes in terms of payments and statutory levies;
(e)	Changes due to any other situation not anticipated;

- 2.23.2 No changes in the price quoted shall be permitted after the purchase order has been issued except on account of statutory variations.
- 2.23.3 No variation or modification in the terms of the contract shall be made except by written amendment signed by the parties.

2.24 Assignment

- 2.24.1 The Supplier shall not assign, in whole or in part, its obligations to perform under the Contract, except with the Purchaser's prior written consent.

2.25 Subcontracts

- 2.25.1 The Supplier shall notify the Purchaser in writing of all subcontracts awarded under this Contract if not already specified in the bid. Such notification, in the original bid or later, shall not relieve the Supplier from any liability or duties or obligation under the contract.

2.26 Extension of time.

- 2.26.1 Delivery of the Goods and performance of the Services shall be made by the Supplier in accordance with the time schedule specified by the Purchaser.
- 2.26.2 If at any time during performance of the Contract, the Supplier or its sub-contractor(s) should encounter conditions impeding timely delivery of the Goods and performance of Services, the Supplier shall promptly notify the Purchaser in writing of the fact of the delay, its likely duration and its cause(s). As soon as practicable after receipt of the Supplier's notice, the Purchaser shall evaluate the situation and may, at its discretion, extend the supplier's time for performance with or without liquidated damages, in which case the extension shall be ratified by the parties by amendment of the Contract.

2.26.3 Except as provided under the Force Majeure clause of the GCC, a delay by the Supplier in the performance of its delivery obligations shall render the Supplier liable to the imposition of liquidated damages pursuant to liquidated damages Clause of the GCC unless an extension of time is agreed upon pursuant to above clause without the application of penalty clause.

2.27 Liquidated Damages

2.27.1 Subject to GCC Clause on Force Majeure, if the Supplier fails to deliver any or all of the Goods or to perform the Services within the period(s) specified in the Contract, the Purchaser shall, without prejudice to its other remedies under the Contract, deduct from the Contract Price, as penalty, a sum equivalent to the percentage specified in SCC of the delivered price of the delayed Goods or unperformed Services or contract value in case the delivered price of the delayed goods or unperformed services cannot be ascertained from the contract, for each week or part thereof of delay until actual delivery or performance, up to a maximum deduction of the Percentage specified in SCC. Once the maximum is reached, the Purchaser may consider termination of the Contract pursuant to GCC Clause on Termination for Default.

2.28 Termination for Default

2.28.1 The Purchaser may, without prejudice to any other remedy for breach of contract, by written notice of default sent to the Supplier, terminate the Contract in whole or part

(a)	If the Supplier fails to deliver any or all of the Goods within the period(s) specified in the contract, or within any extension thereof granted by the Purchaser pursuant to GCC Clause on Extension of Time; or
(b)	If the Supplier fails to perform any other obligation(s) under the Contract.
(c)	If the Supplier, in the judgment of the Purchaser has engaged in corrupt or fraudulent or collusive or coercive practices etc as defined in GCC Clause and ITB clause on code of integrity in competing for or in executing the Contract.

2.28.2 In the event the purchaser terminates the contract in whole or in part, he may take recourse to any one or more of the following action:

(a)	The Performance Security is to be forfeited;
(b)	The purchaser may procure, upon such terms and in such manner as it deems appropriate, stores similar to those undelivered, and the supplier shall be liable for all available actions against it in terms of the contract.
(c)	However, the supplier shall continue to perform the contract to the extent not terminated.

2.29 Force Majeure

2.29.1 Notwithstanding the provisions of GCC Clauses relating to extension of time, Liquidated damages and Termination for Default the Supplier shall not be liable for forfeiture of its performance security, liquidated damages or termination for default, if and to the extent that, its delay in performance or other failure to perform its obligations under the Contract is the result of an event of Force Majeure.

2.29.2 For purposes of this Clause, “Force Majeure” means an event or situation beyond the control of the Supplier that is not foreseeable, is unavoidable, and its origin is not due to negligence or lack of care on the part of the Supplier. Such events may include, but not be limited to, acts of the Purchaser in its sovereign capacity, wars or revolutions, fires, floods, epidemics, quarantine restrictions, and freight embargoes.

2.29.3 If a Force Majeure situation arises, the Supplier shall promptly notify the Purchaser in writing of such conditions and the cause thereof within 21 days of its occurrence. Unless otherwise directed by the Purchaser in writing, the Supplier shall continue to perform its obligations under the Contract as far as is reasonably practical, and shall seek all reasonable alternative means for performance not prevented by the Force Majeure event.

2.29.4 If the performance in whole or in part or any obligations under the contract is prevented or delayed by any reason of Force Majeure for a period exceeding 60 days, either party may at its option terminate the contract without any financial repercussions on either side.

2.30 Termination for Insolvency

2.30.1 The Purchaser may at any time terminate the Contract by giving written notice to the Supplier, if the Supplier becomes bankrupt or otherwise insolvent. In this event, termination will be without compensation to the Supplier, provided that such termination will not prejudice or affect any right of action or remedy, which has accrued or will accrue thereafter to the Purchaser.

2.31 Termination for Convenience

2.31.1 The Purchaser, by written notice sent to the Supplier, may terminate the Contract, in whole or in part, at any time. The notice of termination shall specify that termination is for the Purchaser's convenience, the extent to which performance of the Supplier under the Contract is terminated, and the date upon which such termination becomes effective.

2.31.2 The Goods that are complete and ready for shipment within 30 days after the Supplier's receipt of notice of termination shall be accepted by the Purchaser at the Contract terms and prices. For the remaining Goods, the Purchaser may elect:

(a)	To have any portion completed and delivered at the Contract terms and prices; and/or
(b)	To cancel the remainder and pay to the Supplier an agreed amount for partially completed Goods and for materials and parts previously procured by the Supplier.

2.32 Settlement of Disputes

2.32.1 The Purchaser and the supplier shall make every effort to resolve amicably by direct informal negotiation any disagreement or dispute arising between them under or in connection with the Contract.

2.32.2 If, after twenty-one (21) days, the parties have failed to resolve their dispute or difference by such mutual consultation, then either the Purchaser or the Supplier may give notice to the other party of its intention to commence arbitration, as hereinafter provided, as to the matter in dispute, and no arbitration in respect of this matter may be commenced unless such notice is given. Any dispute or difference in respect of which a notice of intention to commence arbitration has been given in accordance with this Clause shall be finally settled by arbitration. Arbitration may be commenced prior to or after delivery of the Goods under the Contract.

2.32.3 The dispute settlement mechanism/arbitration proceedings shall be concluded as under:

(a)	If any dispute or difference arises between the parties hereto as to the construction, interpretation, effect and implication of any provision of this agreement including the rights or liabilities or any claim or demand of any party against other or in regard to any other matter under these presents but excluding any matters, decisions or determination of which is expressly provided for in this Agreement, such disputes or differences shall be referred to an Arbitral Bench consisting of three Arbitrators, one each to be appointed by each party and the two Arbitrators shall appoint a third Arbitrator who shall be the presiding Arbitrator. A reference to the Arbitration under this Clause shall be deemed to be submission within the meaning of the Arbitration and Conciliation Act, 1996 and the rules framed thereunder for the time being in force. Each party shall bear and pay its own cost of the arbitration proceedings unless the Arbitrators otherwise decides in the Award.
(b)	In the case of a dispute between the purchaser and a Foreign Supplier, the dispute shall be settled by arbitration in accordance with provision of sub-clause (a) above. But if this is not acceptable to the supplier then the dispute shall be settled in accordance with provisions of UNCITRAL (United Nations Commission on International Trade Law) Arbitration Rules.

2.32.4 The venue of the arbitration shall be the place from where the purchase order or contract is issued.

2.32.5 Notwithstanding, any reference to arbitration herein,

(a)	The parties shall continue to perform their respective obligations under the Contract unless they otherwise agree; and
(b)	the Purchaser shall pay the Supplier any monies due the Supplier.

2.33 Governing Language

2.33.1 The contract shall be written in English language which shall govern its interpretation. All correspondence and other documents pertaining to the Contract, which are exchanged by the parties, shall be written in the English language only.

2.34 Applicable Law

2.34.1 The Contract shall be interpreted in accordance with the laws of the Union of India and all disputes shall be subject to place of jurisdiction as specified in SCC.

2.35 Notices

2.35.1 Any notice given by one party to the other pursuant to this contract/order shall be sent to the other party in writing or by cable, telex, FAX, e-mail or and confirmed in writing to the other party's address specified in the SCC.

2.35.2 A notice shall be effective when delivered or on the notice's effective date, whichever is later.

2.36 Taxes and Duties

2.36.1 For goods manufactured outside India, the Supplier shall be entirely responsible for all taxes, stamp duties, license fees, and other such levies imposed outside India.

2.36.2 For goods Manufactured within India, the Supplier shall be entirely responsible for all taxes, duties, license fees, etc., incurred till its final manufacture/production.

2.36.3 If any tax exemptions, reductions, allowances or privileges may be available to the Supplier in India, the Purchaser shall make its best efforts to enable the Supplier to benefit from any such tax savings to the maximum allowable extent without any commitment.

2.36.4 **All payments due under the contract shall be paid after deduction of statutory levies (at source) (like TDS, IT, TCS etc.) wherever applicable. In this connection Gol notification may be referred to before submitting quote on their own interest. Statutory deductions will be done accordingly at the time of payment.**

2.36.5 **Customs Duty:**

a) If the supply is from abroad this Institute is permitted to import goods as per notification No.51/96 – Customs and pay a concessional duty up to 5% plus surcharges, if any as per notification 24/2002 – Customs on all imports.

b) The Certificates is issued without any commitment by CSIR-NAL. Hence, the supplier should ensure its applicability for their own interest.

2.36.6 **GST**

(a) The Purchaser is registered with Dept. of Scientific & Industrial Research, Govt. of India and concessional customs duty and GST & IGST are leviable vide notification No. 54/2002- Customs on all imports covered under Notification No.51/96-Customs dated 23.07.1996, Notification No.47/2017-Integrated Tax (Rate) and Notification No. 45/2017-Central Tax (Rate) both dated 14th November, 2017.

(b) The Certificates is issued without any commitment by CSIR-NAL. Hence, the supplier should ensure its applicability for their own interest.

2.37 Right to use Defective Goods

2.37.1 If after delivery, acceptance and installation and within the guarantee and warranty period, the operation or use of the goods proves to be unsatisfactory, the Purchaser shall have the right to continue to operate or use such goods until rectifications of defects, errors or omissions by repair or by partial or complete replacement is made without interfering with the Purchaser's operation.

2.38 [Protection against Damage](#)

2.38.1 The system shall not be prone to damage during power failures and trip outs. The normal voltage and frequency conditions available at site as under:

(a)	Voltage 230 volts – Single phase/ 415 V 3 phase (+_ 10%)
(b)	Frequency 50 Hz.

2.39 [Site preparation and installation](#)

2.39.1 The Purchaser is solely responsible for the construction of the equipment sites in compliance with the technical and environmental specifications defined by the Supplier. The Purchaser will designate the installation sites before the scheduled installation date to allow the Supplier to perform a site inspection to verify the appropriateness of the sites before the installation of the Equipment, if required. The supplier shall inform the purchaser about the site preparation, if any, needed for installation, of the goods at the purchaser's site immediately after notification of award/contract.

2.40 [Import and Export Licenses](#)

2.40.1 If the ordered materials are covered under restricted category of EXIM policy in India the Bidder/ Agent may intimate such information for obtaining necessary, license in India.

2.40.2 If the ordered equipment is subject to Bidder procuring an export license from the designated government agency / country from where the goods are shipped / sold, the vendor has to mention the name, address of the government agency / authority. The Bidder must also mention the time period within which the license will be granted in normal course.

2.41 [Risk Purchase Clause](#)

2.41.1 If the supplier fails to deliver the goods within the maximum delivery period specified in the contract or Purchase Order, the purchaser may procure, upon such terms and in such a manner as it deems appropriate, Goods or Services similar to those undelivered and the Supplier shall be liable to the purchaser for any excess costs incurred for such similar goods or services.

2.42 [Option Clause](#)

2.42.1 The Purchaser reserves the right to increase or decrease the quantity of the required goods up to 25% (Twenty-Five) per cent at any time, till final delivery date (or the extended delivery date of the contract), by giving reasonable notice even though the quantity ordered initially has been supplied in full before the last date of the delivery period (or the extended delivery period)

2.43 [Integrity Pact](#)

2.43.1 The SCC shall specify whether there is a need to enter into a separate Integrity pact or not.

2.43.2 The names and contact details of the Independent External Monitors (IEM) on the event of the need of IP is as detailed in the SCC.

2.44 [Order Acceptance](#)

2.44.1 The successful bidder should submit Order acceptance **within 14 days from the date of issue of order/signing of contract**, failing which it shall be presumed that the Bidder is not interested and his bid security is liable to be forfeited pursuant to clause 1.16.9 of ITB.

CHAPTER 2

SPECIAL CONDITIONS OF CONTRACT (SCC)

The following Special Conditions of Contract (SCC) shall supplement and / or amend the General Conditions of Contract (GCC). Whenever there is a conflict, the provisions herein shall prevail over those in the GCC.

Sl.No.	GCC Clause Ref	Condition
1	GCC 2.1.1(l)	<p>The Purchaser is: The Director CSIR- National Aerospace Laboratories HAL Airport Road, Kodihalli, Bengaluru – 560017 Karnataka-India Tel #: 00 91 80 2508 6097/6710 E-mail: purchasecadd@nal.res.in</p> <p>Bill to address is same as above</p>
2	GCC 2.1.1(m)	<p>The Final Destination is: CSIR- National Aerospace Laboratories HAL Airport Road, Kodihalli, Bengaluru – 560017 Karnataka-India Tel #: 00 91 80 2508 6097/6710 E-mail: purchasecadd@nal.res.in</p>
3	GCC 2.13.1	<p>Performance Security</p> <p>The amount of the Performance Bank Guarantee shall be 3% of the contract value to be submitted within 21 days from the date of PO valid up to 60 days after the date of completion of performance obligations including warranty obligations.</p>
4	GCC 2.16.3	<p>Delivery – Mode of Transportation/Shipment</p> <p>a) In case of supplies from within India, the mode of transportation shall be by Road.</p>
5	GCC 2.17.1	<p>Insurance</p> <p>The Insurance shall be for an amount equal to 110% of the invoice value of the contract from “warehouse to warehouse (final destination)” on “all risk basis” including strikes, riots and civil commotion.</p>
6	GCC 2.21.3	<p>The period of validity of the Warranty shall be</p> <p>The Warranty details are as per Chapter-4</p>
7	GCC 2.22.1	<p>Payment Terms</p> <p>The method and conditions of payment to be made to the Supplier under this Contract shall be as follows:</p> <p>A Payment for Goods and Services supplied from India</p> <p>The payment shall be made in Indian Rupees, as follows:</p> <p>(a) 100% after Supply, Installation, Commissioning, Training and Acceptance, subject to validity of Performance Security to cover warranty obligations</p> <p>(b) 100% through Inland Letter of Credit opened in favour of supplier through CSIR-NAL Bank (State Bank of India), will be decided, as the case may be.</p> <p>(c) E-Payment: All payments, CSIR-NAL prefers to make Electronic Transfers (RTGS) through State Bank Of India, NAL Branch, Bengaluru.</p> <p>(d) All payments due under the Contract shall be paid after deduction of statutory levies at source (like TDS, Income Tax, etc.), wherever applicable.</p>
8	GCC 2.27.1	<p>Liquidated Damages</p> <p>(a) If the Supplier fails to Supply, Install and Commission the system as per specifications mentioned in the order within the due date including training, the Supplier is liable to pay penalty of 0.5% of order value per week or part of a week.</p> <p>(b) The maximum amount of penalty shall be 10%</p>
9	GCC 2.34.1	Applicable Law / Jurisdiction

		The place of jurisdiction is Bengaluru , India.
10	GCC 2.35.1	For notices, the Purchaser's address is The Director Attention: Sr. Controller of Stores & Purchase CSIR- National Aerospace Laboratories PB No.1779, HAL Airport Road, Kodihalli, Bengaluru – 560017 Karnataka-India Tel #: 00 91 80 2508 6097/6710 Email: purchasercadd@nal.res.in
11	GCC 2.43.1	Integrity Pact - The integrity pact is not to be signed . However, efforts must be made to realize the objectives & spirits thereof.

CHAPTER 3

(To be filled by the bidder and enclosed with the Technical Bid)

SCHEDULE OF REQUIREMENT

The Schedule of Requirement must clearly specify **the time frame required (Schedule) for delivery of goods and services to be completed** by the bidder (in reference to Scope of Supply given in Clause-4.2 of Chapter-4) if the Contract is awarded for the offer / proposal submitted by the bidder in response to this Tender.

A) **Delivery Schedule:**

Sr. No.	Brief Description of Goods and Services	Quantity & Unit	Delivery Schedule

B) **Period of delivery shall start from** : _____

C) **Term of Delivery / Delivery Term (named port of shipment or named place of delivery:**

Goods from Abroad	
Goods from India	

D) **Scope of Supply:**

E) **Time frame required for conducting installation, commissioning of the equipment, acceptance test, training, etc. after the arrival of consignment or before dispatch of equipment:**

Sr. No.	Activity	Time Frame
1	Site Preparation (if required)	
2	Installation & Commissioning	
3	Acceptance Test	
4	Training (Location, No. of persons, period of training, nature of training)	
5		

Place : _____

Signature of the Bidder : _____

Date : _____

Notes for Bidders:

(1)	The delivery schedule shall clearly indicate the time period within which the successful bidder must deliver the consignment in full from the date of establishment of LC or from the date of contract or from the date of advance payment etc. It should also indicate separately the time period desired for installation and commissioning of the equipment after arrival of the consignment at the premises of the Purchaser.
(2)	The date or period for delivery should be carefully specified, taking into account
(3)	The implications of delivery terms stipulated in the Instructions to Bidders pursuant to the Incoterms rules (i.e., EXW, or CIF, CIP, FOB, FCA terms—that “delivery” takes place when goods are delivered to the carriers), and
(4)	The date prescribed herein from which the delivery obligations start (i.e., notice of award, contract signature, opening or confirmation of the letter of credit, date of releasing advance payment etc.).

CHAPTER 4

Specifications and Allied Technical Details for Hydraulic Power Pack (HPP)

4.1 End Use:

The CNC SERVO Hydraulic Press Brake shall be utilized to carry out forming of ferrous, non-ferrous and super alloys for various projects undertaken by CSIR-NAL. The said equipment shall be installed and commissioned at CSIR-NAL, Kodihalli campus, Bengaluru.

Note: Bidder Shall provide the compliance statement in the tabular format only. Appropriate Values shall be furnished wherever possible.

4.2 Detailed Technical Specification (including the list of spares):

Sl.No.	DESCRIPTION	SPECIFICATION
A.	MACHINE DESCRIPTION :	
1	CNC Hydraulic Press Brake shall be capable of bending up to 4mm thick Aluminium alloy plate with a width of 3000 mm .	Required
2	The machine configuration Y1-Y2 (for RAM) and X (for back gauge) to handle a wide variety of sheet metal forming jobs shall be provided.	Required
3	The machine shall be of down stroking, electric closed loop and servo valve controlled system.	Required
4	The RAM shall be fully guided throughout the entire stroke guides with proper lubrication with linear encoder for RAM feedback and positioning	Required
5	The machine shall have CNC back gauge with safety features for two finger stop.	Required
6	The machine shall be supplied with One set of tooling consisting of Multi V die & punch segmented (European style tooling hardened & ground). List of Tools to be supplied is enclosed in ANNEXURE-1	Required
7	The machine shall have servo hydraulic system. First fill of oil and Lubrication for the power pack / Hydraulic system shall be provided by the vendor.	Required
8	The machine shall be provided with Hardened Ground Ball Screw and Linear Motion (LM) bearing for better positional accuracy, repeatability and longer life.	Required
B.	GENERAL FEATURES OF MACHINE:	
1	The machine frame shall be of stress relieved rigid steel construction for minimum deflection under full load condition.	Required
2	The Machine shall be equipped with suitable signal /indication lamps.	Required
3	The machine shall be provided with good centralized Lubrication system with flow control valves for better lubrication of the sliding parts and better life.	Required
4	Suitable Electrical Cabinet equipped with air conditioning unit (if required) shall be provided which shall operate at the environmental temperature of 50°C Max. and humidity up to 95%	Required
5	Maintenance / Diagnostic facilities are to be incorporated in the CNC System. The machine shall be designed to adapt both European and American style of tooling.	Required
6	Operator station shall be conveniently positioned near the machine to carry out the machine operation.	Required
C.	TECHNICAL DATA: (A printed catalogue must be attached)	
1	CAPACITY:	
2	Tonnage	100 Metric Tons or more
3	Bending Capacity	4mm x 3000mm or More (Aluminum alloy sheet)
4	Clear Pass	3000mm or better
5	Table Size	1700mm x 3000mm or more

6	Standard Stroke	150mm or more
7	Open Height	350mm or more
8	Throat	200 mm or more
9	Minimum RAM Speed	
	a. Approach	100 mm/sec or more
	b. Pressing (adjustable)	5 mm / sec or more
	c. Return	60mm/ sec or more
10	Motor (kW)	7.5kW or more
11	Back gauge X-Axis Travel	600 mm or more
12	CNC controlled RAM motion Y-Axis Travel	200 mm or more
13	RAM synchronous motion (Y1 and Y2) for dual cylinder hydraulic system	Required
14	Manual micro adjustment for other non-controlled axes separately	Required
D	CNC CONTROL SYSTEM:	
1	The CNC system shall be of latest configuration, user friendly, easily programmable with PC Architecture. The vendor shall specify the Make/model of CNC controller with current version of software. Any up gradation of Software during the warranty period shall be provided free of cost. If the software is found corrupt during the warranty period, the software shall be reinstalled at no cost to CSIR-NAL.	Required
2	LCD/LED Screen display with alpha numeric key pad shall be provided.	Required/Specify
3	Manual, Auto, & Program Mode selection.	Required
4	Bend Angle & Depth mode program with Stroke Control & Stroke Counter on Screen.	Required
5	Shall be capable of storing minimum 24 programs & minimum 8 bends per program	Required
6	Shall have Automatic bending sequencing feature.	Required
7	Technical Parameter/ Database to be available for reference , If any	Required
8	New Tool defining capability.	Required
9	Collision detection.	Required
10	Movable Work Station with Pair of Footswitch	Required
11	Data Interface facility through USB port for input /output shall be provided as standard.	Required
12	System equipped with CNC and Logic software.	Required
13	Program manager shall have editing options along with copy, paste, delete, etc.	Required
14	LAN setting for Data transfer	Required
15	RS-232-C port /Ethernet	Required
E	ESSENTIAL DISPLAY FEATURES ON THE SCREEN:	
1	Machine position (RAM Position)	Required
2	Program under execution.	Required
3	Distance to go.(RAM Movement)	Required
4	Error message viz.Limit switch failure, Power pack failure, Oil leakages and excess oil temperature etc. shall be displayed on the screen.	Required

F	SAFETY FEATURES:	
1	Inter-locking arrangement against faulty sequence of operation. Front light curtain to be provided for protecting operator fingers	Required
2	Limits /alarm for Overload , force , torque shall be provided	Required/Specify
3	Protection against high/low voltage shall be provided	Specify
4	Hydraulic oil temperature sensor and Safety Package for Power Failure shall be provided	Specify
G	SERVICE SUPPORT :	
1.	Service support for the entire machine along with the CNC control system shall be available in India. Any fault /complaint shall be attended within a period of 3(Three) working days from the date of intimation through E-Mail/ Phone/ Fax.	Required
2	Full service support including repairing/reconditioning of Machine, PCB's , CNC control system ,drives and Controller Software shall be available for at least 10 (ten) years from the date of commissioning of the machine.	Required
3	Spare support of all mechanical, electrical, CNC system and drives shall be available at least for 10 years from the date of commissioning of the machine at site.	Required
H	DOCUMENTATION:	
1	Two sets of hardcopy in English language and one set of soft copy in English language(One CD/DVD) of the following documents shall be provided	Required
2	Programming and operating manuals.	Required
3	Maintenance Manual	Required
4	Drives Manual, PLC manuals, PLC data. Inputs and outputs configuration details and their traceability & PLC Reading, Editing, Debugging, Downloading and uploading feature, alarms and remedies	Required
5	Machine Electrical & Electronics Manual with wiring diagram	Required
6	Mechanical Manual , Drawings along with item details and List	Required
7	Complete backup of machine data, general and optional commissioning data.	Required
8	Hydraulic & Pneumatic Manual with Layout Diagram	Required
I	ESSENTIAL ACCESSORIES:	
1	Hardened and ground (45 HRC) Multi V die & punch to suit from 1mm to 4 mm thick Aluminum Alloy sheet in appropriate steps with European style tooling and American style of tooling adapter shall be provided . The die and punch combination set shall be able to carry out common sheet metal bending operations like air bending, coining , flattening and hemming. NOTE : List of tools to be supplied is enclosed in ANNEXURE-1	1 set Required
2	Suitable material adjustable feed table (It should have wheels / rollers for Movement of sheet)	Required
3	Front & Rear Sheet Support (Adjustable)	Required
4	Motorized Anti-Deflection System	Required
J	GENERAL INSTRUCTIONS:	
1	The basic machine cost shall include all essential items needed to comply the above specifications, installation & commissioning, training at CSIR-NAL after installation and proves out of components .	Required
2	The prices of the all optional items shall be quoted separately.	Specify
3	For the Purpose of Price Comparison , the Cost of the Basic Machine Plus essential Accessories shall be considered(Please refer Price Schedule form of chapter 5)	Required
4	The vendor shall provide catalogue / drawings of the items offered.	Required

5	The vendor shall quote for the model / machines which are the standard products of proven design And its catalogue shall be enclosed.	Required
6	Deviation in specification , if any , may be intimated by providing proper justification for each deviation separately (refer deviation statement form ANNEXURE-H , chapter 8 of the tender document)	Required
7	Vendors should also specifically mention the Total Power requirement for the machine, over all dimensions of the machine (Space requirement), Weight of the machine etc. immediately after Placing the Purchase order.	Required
8	The Power pack shall be provided with portable pumping arrangement for easy loading and unloading of hydraulic oil.	Required
K	POWER SUPPLY CONDITIONS AT CSIR-NAL :	415V, 3 phase, 50 Hz, 4 wire supply
	Variations in voltage Frequency fluctuation The system must be able to function under the above fluctuations of voltage and frequency	-15% to +10% +/- 2Hz
L	LIST OF SPARES : The vendor may please quote for all the essential spares required for the press.	Required
M	ACCURACIES OF THE MACHINE :	
1	The Vendor shall carry out the tests for performance and accuracy of the CNC Servo Hydraulic Press brake as per JIS: B 6403-1077- Class 1 standard (Reaffirmed: 1985) and submit the report to CSIR-NAL.	
2	X-Axis & Y-Axis positional Accuracy	± 0.05 mm or less
3	X-Axis & Y-Axis repeatability	0.05mm or less
4.	Flatness of the work table Top(Horizontal) for a size of (3000mm X 500 mm)	0.02mm or less
5.	The Vertical angle between the slide stroke and the work top	0.25 degree or less
N	PROVE OUT COMPONENTS AT SUPPLIER'S PLACE :	
1.	The vendor shall fabricate 1(One) sets of the components as per the drawings enclosed in ANNEXURE -2 . All the necessary tooling/Jigs and Raw material required for Proving out the components shall be arranged by the Vendor.	Required
O.	CLEARANCE FOR DISPATCH OF THE MACHINE FROM VENDOR'S SITE :	
1.	The Test reports for performance and accuracy as per Sl. No M (1,2,3,4&5) and the components fabricated as per Sl. No. N(1) shall be dispatched to CSIR-NAL along with the Dimensional inspection reports. On successful acceptance of the components, test and accuracies reports by CSIR-NAL, the machine shall be cleared for dispatch.	Required
P	OTHER POINTS :	
1.	Delivery Schedule	120 days from the date of placement of Order
2.	Make /model of the Electrical Main Motors	Siemens/ABB/Crompton Greaves or equivalent
3.	Make/Model of the Electrical Components	Siemens/Schneider or equivalent
4.	Make/Model of the Hydraulic system/Pumps	Bosch Rexroth, Yuken,Voith or equivalent

<p>4.3 <u>Scope of Supply and incidental works</u></p>
<p>Scope of Supply includes the following:</p> <ol style="list-style-type: none"> 1. Supply of the equipment /machine as specified in 4.1 and 4.2 above 2. Installation & Commissioning: The scope of supply shall include installation and commissioning and prove out of components on the machine at CSIR-NAL. The supplier shall arrange all the necessary material handling equipments and manpower for installation of the machine at the designated site in CSIR-NAL, Kodihalli, Bengaluru at no cost to CSIR-NAL. Electrical Power Supply shall be provided by NAL for Installation and commissioning activities . 3. Training as specified below in clause 4.5 below. 4. On site comprehensive Warranty as specified in clause 4.6 below
<p>4.4 <u>Inspection & Tests:</u></p>
<p>4.4.1 <u>General</u></p>
<ol style="list-style-type: none"> 1. The Supplier shall at its own expense and at no cost to the Purchaser carry out all such tests and/or inspections of the Goods and Related Services as are specified here. 2. The inspections and tests may be conducted on the premises of the Supplier or its subcontractor(s), at the point of delivery and/or at the Goods final destination. 3. Whenever the Supplier is ready to carry out any such test and inspection, it shall give a reasonable advance notice, including the place and time, to the Purchaser. The Supplier shall obtain from any relevant third party or manufacturer any necessary permission or consent to enable the Purchaser or its designated representative to attend the test and/or inspection. 4. Should any inspected or tested Goods fail to conform to the specifications, the Purchaser may reject the goods and the Supplier shall either replace the rejected Goods or make alterations necessary to meet specification requirements free of cost to the Purchaser. 5. The Purchaser's right to inspect, test and, where necessary, reject the Goods after the Goods' arrival at final destination shall in no way be limited or waived by reason of the Goods having previously been inspected, tested and passed by the Purchaser or its representative prior to the Goods shipment. 6. The Supplier shall provide the Purchaser with a report of the results of any such test and/or inspection. 7. With a view to ensure that claims on insurance companies, if any, are lodged in time, the bidders and/or the Indian agent, if any, shall be responsible for follow up with their principals for ascertaining the dispatch details and informing the same to the Purchaser and he shall also liaise with the Purchaser to ascertain the arrival of the consignment after customs clearance so that immediately thereafter in his presence the consignment could be opened and the insurance claim be lodged, if required, without any loss of time. Any delay on the part of the bidder/ Indian Agent would be viewed seriously and he shall be directly responsible for any loss sustained by the purchaser on the event of the delay. 8. Before the goods and equipment are taken over by the Purchaser, the Supplier shall supply operation and maintenance Manuals together with Drawings of the goods and equipment built. These shall be in such details as will enable the Purchase to operate, maintain, adjust and repair all parts of the works as stated in the specifications. 9. The Manuals and Drawings shall be in the ruling language (English) and in such form and numbers as stated in the Contract. 10. Unless and otherwise agreed, the goods and equipment shall not be considered to be completed for the purposes of taking over until such Manuals and Drawing have been supplied to the Purchaser. 11. On successful completion of acceptability test, receipt of deliverables, etc. and after the Purchaser is satisfied with the working of the equipment, the acceptance certificate signed by the Supplier and the representative of the Purchaser will be issued. The date on which such

<p>certificate is signed shall be deemed to be the date of successful commissioning of the equipment.</p>
<p>4.4.2 <u>Manufacturer's Inspection Certificate:</u></p> <p>After the goods are manufactured and assembled, inspection and testing of the goods shall be carried out at the supplier's plant by the supplier, prior to shipment to check whether the goods are in conformity with the technical specifications. Manufacturer's test certificate with data sheet shall be issued to this effect and submitted along with the delivery documents. The purchaser reserves the options to be present at the supplier's premises during such inspection and testing.</p> <p>a. CALIBRATION: The machine shall be calibrated in Metric system only. Appropriate test charts must be supplied /furnished along with the machine.</p> <p>b. The machine shall be inspected for its geometrical accuracies and performance as per JIS:B-6403-1077-Class-1(reaffirmed: 1985) standards other than the accuracies specified in Sl. No. M (1, 2, 3, 4&5).</p> <p>Note: The Calibration test reports, test charts, performance reports and inspection report of the CNC Servo Hydraulic Press Brake and Proved Out Components with their inspection reports [Sl. No. N(1)]as per the Purchase order shall be dispatched to CSIR-NAL for studying the accuracies and performance of the Machine. After obtaining necessary clearance/approvals from CSIR-NAL, the machine along with all the Accessories, tooling etc. shall be supplied to CSIR-NAL, Bengaluru.</p>
<p>4.4.3 <u>Acceptance Test :</u></p> <p>The acceptance test will be conducted by the Purchaser, their consultant or other such person nominated by the Purchaser at its option after the equipment is installed at Purchaser's site in the presence of supplier's representatives. The acceptance will involve trouble free operation. There shall not be any additional charges for carrying out acceptance test. No malfunction, partial or complete failure of any part of the equipment is expected to occur. The Supplier shall maintain necessary log in respect of the result of the test to establish to the entire satisfaction of the Purchaser, the successful completion of the test specified.</p> <p>On the event of the ordered item failing to pass the acceptance test, a period not exceeding two weeks will be given to rectify the defects and clear the acceptance test, failing which, the Purchaser reserve the right to get the equipment replaced by the Supplier at no extra cost to the Purchaser. Successful conduct and conclusion of the acceptance test for the installed goods and equipment shall also be the responsibility and at the cost of the Supplier.</p>
<p>4.4.3(I) <u>Installation and Commissioning of the machine at CSIR-NAL</u></p> <p>a. The machine shall be installed at the designated site in CSIR-NAL, APMF, Kodihalli Campus, Bengaluru.</p> <p>b. Vendor shall make all necessary arrangement like material Handling equipments, Tools, Cranes, Manpower etc. required for Installation and commissioning of the machine at the designated site.</p> <p>c. The Vendor shall visit the site before installation after placement the purchase order and shall provide the Foundation/ Installation details within 15 days after placement of purchase order.</p> <p>NOTE: The foundation work (Civil Work) if any, shall be carried out by CSIR-NAL, Bengaluru as per the drawing provided by the vendor.</p>
<p>4.4.3(II) <u>The acceptance Tests at CSIR-NAL Include the following:</u></p> <p>a. The machine shall be inspected for its geometrical accuracies and performance as per JIS:B-6403-1077-Class-1(reaffirmed: 1985) standards other than the accuracies specified in Sl. No. M (1, 2, 3, 4&5).The calibrated measuring instruments required to carry out the said inspection/tests shall be brought by the vendor.</p> <p>b. The Dimensional Parameters shall be checked as per the Purchase order.</p> <p>C. PROVE OUT OF COMPONENTS AT CSIR- NAL: The vendor shall fabricate 1(One) sets of the components as per the drawings enclosed in ANNEXURE -2 after installation and Commissioning of the machine at CSIR-NAL. All the necessary tooling/Jigs and Raw material required for proving out the components shall be arranged by the Vendor.</p>
<p>4.5 <u>Training:</u></p> <p>I. <u>Training at CSIR-NAL :</u></p> <p>The vendor shall provide training on programming, operation, trouble shooting, maintenance etc. to CSIR- NAL staff.</p> <p>a. No. of staff Members: 4 (four) members</p> <p>b. Period : 5 (FIVE) working days</p>

4.6 Warranty:

The complete machine along the CNC Controller shall have a comprehensive warranty for a period of **24 months** (Twenty-four months) from the date of successful completion of installation, commissioning and acceptance tests at CSIR-NAL. During the warranty period upgrades of the software, if any shall be provided free of cost.

The Vendor shall replace defective items / parts of the machine and CNC Controller as a whole depending on degree of defect noted free of cost during warranty period.

4.7 Annual Maintenance Contract (OPTIONAL):

The Vendor shall quote for Comprehensive Annual maintenance contract separately for a period of 2(Two) years after completion of the warranty period. However, the cost of the AMC will not be considered for establishing the lowest bidder.

LIST OF TOOLS – ANNEXURE-1

1.88° (degree) to 90° (degree) goose neck punches /top tools

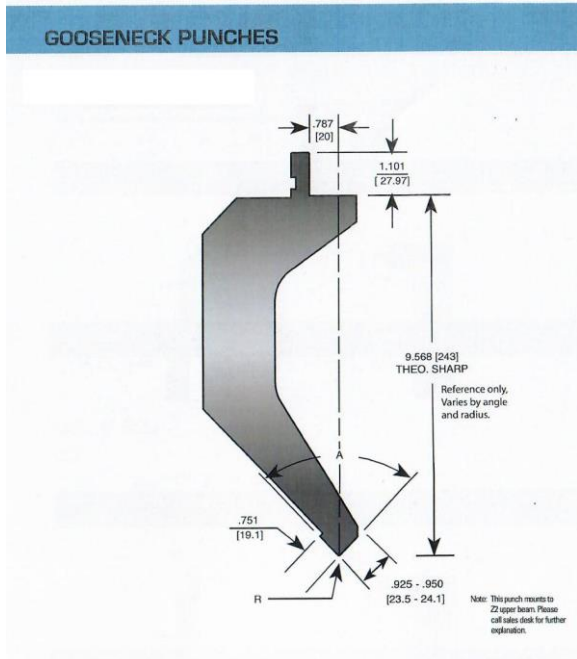

- a. Optimum materials such as C45, CrMo, etc hardened to 45HRC.
- b. Bending radius hardened up to 50 HRC.
- c. The Punch Shall be precisely ground and Interchangeable.

1. MULTI V – DIE – 1 No.

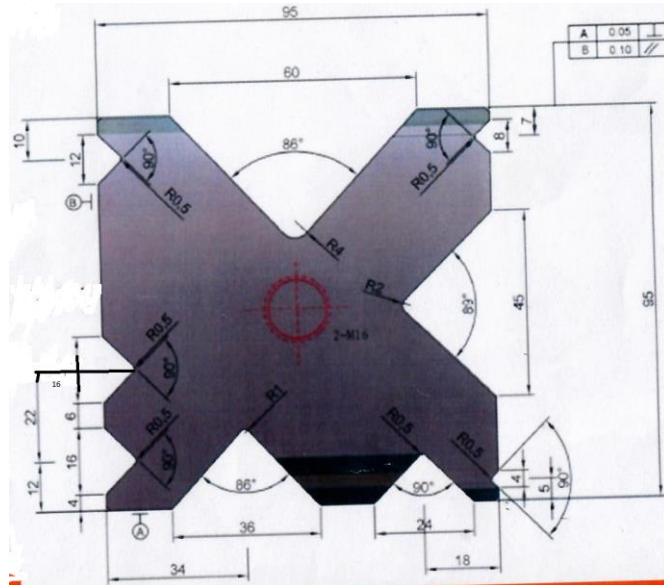

- a. Length - 3000 mm
- b. Optimum materials such as C45, CrMo, etc. hardened and ground, Hardness :45-50 HRC.
- c. All faces/ grooves shall be Precisely ground & Parallelism to be maintained .

Prove out of components -ANNEXURE-2

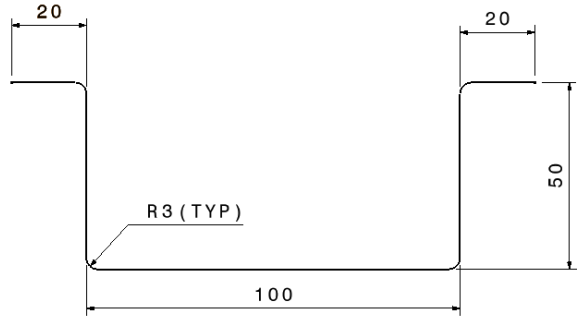
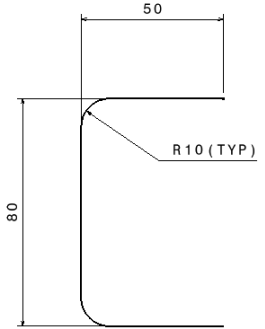
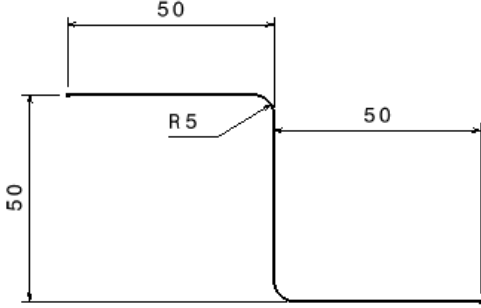
	
<p>(i) Drawing No: APMF/01 Material: Aluminum alloy 'O' condition Thickness: 2mm Length: 1500mm</p>	<p>(ii) Drawing No: APMF/02 Material: Aluminum alloy 'O' condition Thickness: 4mm, Length: 1500mm</p>
	
<p>(iii) Drawing.No: APMF/03 Material: Aluminum alloy 'O' condition Thickness : 3 mm ,Length : 1500 mm</p>	

CHAPTER-5

PRICE SCHEDULE FORMS

Bidder should quote as per the BOQ Format Only as uploaded in <https://etenders.gov.in>

Note:

- i. The Bidder may fill the BoQ (Price Schedule Form) and enclose as per Clause 1.10 and 1.18.3 of the Bidding documents.
- ii. The Non-Relevant Cells in Column M have to be filled with 0 (Zero) before Uploading the BoQ.

CHAPTER-6

Qualification Requirements

Criteria 1 - Experience and Past Performance:

- a) 'The bidder' (manufacturer or principal of authorized representative – hereinafter referred simply as 'The Bidder') should have regularly for at least the last 10(Ten) years, ending 31st March of the previous financial year (hereinafter called 'The relevant Date'), manufactured and supplied (/erected/ commissioned" CNC HYDRAULIC PRESS BRAKES with the same or higher specifications/parameters (hereinafter called 'The Product'). The bidder should submit the manufacturer authorisation form as appended in Chapter-8 and
- b) 'The bidder' should have manufactured and supplied (/erected/commissioned) at least 10(Ten) numbers (herein after referred as 'The Qualifying Quantity') of The Product in the last five years ending on 31 March 2021. and out of which
- c) At least **2(Two) numbers** of offered version/model of the CNC Hydraulic Press Brake should be in successful operation for at least **2(Two)** years on the date of bid opening.

Criteria 2 - Capability- Equipment & manufacturing Facilities:

'The bidder' must have an annual capacity to manufacture and supply (/erected/ commissioned) at least 5(five) (The Qualifying Quantity)

Criteria 3 - Financial Standing – under all conditions

- a) The average annual financial turnover of 'The bidder' during the last three years, ending on 'The relevant Date', should be at ₹20,00,000/- as per the annual report (audited balance sheet and profit & loss account) of the relevant period, duly authenticated by a Chartered Accountant/Cost Accountant in India or equivalent in relevant countries.

Ministry of MSME have clarified that all Central Ministries/Departments/Central Public Section Undertakings may relax condition of prior turnover and prior experience with respect to Micro and Small Enterprises in all public procurements subject to meeting of quality and technical specifications. Further, the condition of prior turnover and prior experience may be relaxed for Start-ups (as defined by Department of Industrial Policy and Promotion) subject to meeting of quality & technical specifications and making suitable provisions in the bidding document (rule 173 (i) of GFR 2017))

- b) The net worth of the Bidder firm (manufacturer or principal of authorized representative) should not be negative on 'The Relevant Date' and also ii) should have not eroded by more than 30% (thirty percent) in the last three years, ending on 'The Relevant Date'.

Applicability in Special Cases:

- a) Applicability to 'Make in India': Bidders (manufacturer or principal of authorised representative) who have a valid/approved ongoing 'Make in India' agreement/program and who while meeting all other criteria above, except for any or more of sub-criteria in Experience and Past Performance above, would also be considered to be qualified provided:
- i) their foreign 'Make-in-India' associates meet all the criteria above without exemption, and
 - ii) the Bidder submits appropriate documentary proof for a valid/approved ongoing 'Make in India' agreement/program.
 - iii) the bidder (manufacturer or principal of authorised representative) furnishes along with the bid a legally enforceable undertaking jointly executed by himself and such foreign Manufacturer for satisfactory manufacture, Supply (and erection, commissioning if applicable) and performance of 'The Product' offered including all warranty obligations as per the general and special conditions of contract.
- b) Authorized Representatives: Bids of bidders quoting as authorised representative of a principal manufacturer would also be considered to be qualified, provided:
- i) their principal manufacturer meets all the criteria above without exemption, and
 - ii) the principal manufacturer furnishes a legally enforceable tender specific authorisation in the prescribed form assuring full guarantee and warranty obligations as per the general and special conditions of contract; and
 - iii) the bidder himself should have been associated, as authorised representative of the same or other Principal Manufacturer for same set of services as in present bid (supply, installation, satisfactorily commissioning, after sales service as the case may be) for same or similar 'Product' for past three years ending on 'The Relevant Date'.
- c) Joint Ventures and Holding Companies: Credentials of the partners of Joint ventures cannot (repeat cannot) be clubbed for the purpose of compliance of PQC in supply of Goods/Equipment, and each partner must comply with all the PQC criteria independently. However, for the purpose of qualifying the Financial Standing Criteria, the Financial Standing credentials of a Holding Company can be clubbed with only one of the fully owned subsidiary bidding company, with appropriate legal documents proving such ownership.

Note for Bidders:

- a) 'Doctrine of Substantial Compliance': The Pre-Qualification Bidding (PQB) and Pre-Qualification Criteria (PQC) are for shortlisting of sources who are competent to perform this contract to ensure best value for money from expenditure of Public Money. This process is neither intended to bestow any entitlement upon nor to create any rights or privileges for the Bidders, by way of overly hair-splitting or viciously legalistic interpretations of these criteria, disregarding the very rationale of the PQB and PQC. Keeping this caveat in view, interpretation by the Purchaser would be based on common usage of terminologies and phrases in public procurement in accordance with the 'Doctrine of Substantial Compliance' and would be final.

- b) The Bidder must declare, whether asked or not in a bid document, any previous transgressions of such a code of integrity with any entity in any country during the last three years or of being debarred by any other Procuring Entity. Failure to do so would amount to violation of this code of integrity.
- c) In case of agents quoting in offshore procurements, on behalf of their principal manufacturers, one agent cannot represent two manufacturers or quote on their behalf in a particular tender enquiry. One manufacturer can also authorise only one agent/ dealer. There can be only one bid from the following:
 - i) The Principal manufacturer directly or through one Indian agent on his behalf; and
 - ii) Indian/foreign agent on behalf of only one principal.
- d) Along with all the necessary documents/certificates required as per the tender conditions, the bidder should furnish a brief write-up, backed with adequate data, explaining his available capacity (both technical and financial), for manufacture and supply of the required goods/equipment, within the specified time of completion, after meeting all their current commitments.
- e) Supporting documents submitted by the bidder must be certified as follows:
 - i) All copy of supply/work order; respective completion certificate and contact details of clients; documents issued by the relevant Industries Department/National Small Industries Corporation (NSIC)/ manufacturing licence; annual report, etc., in support of experience, past performance and capacity/capability should be authenticated by the by the person authorised to sign the tender on behalf of the bidder. Original Documents must be submitted for inspection, if so demanded.
 - ii) All financial standing data should be certified by certified accountants, for example, Chartered Accountants/Cost Accountants or equivalent in relevant countries; and Indian bidder or Indian counterparts of foreign bidders should furnish their Permanent Account Number.
- f) A bidder or any of its affiliates who participated as a consultant in the preparation of the design or technical specifications of the contract i.e. the subject of the bid; cannot participate in the bidding process.
- g) Indian agents quoting on behalf of its foreign principal need to submit an copy of the agency agreement with the foreign principal detailing the services to be rendered by them on behalf of the principals, failing which its bid shall not be considered.
- h) Foreign bidders to disclose the name and address of agent and representatives in India and Indian bidder to disclose their foreign principal or associates.

CHAPTER 7
Contract Form

Contract No. _____ Date: _____

THIS CONTRACT AGREEMENT is made
the [insert: number] day of [insert: month], [insert: year].

BETWEEN

- (1) The Council of Scientific & Industrial Research registered under the Societies Registration Act 1860 of the Government of India having its registered office at 2, Rafi Marg, New Delhi-110001, India represented by National Aerospace Laboratories, Bengaluru (hereinafter called “the Purchaser”), and
- (2) [insert name of Supplier], a corporation incorporated under the laws of [insert: country of Supplier] and having its principal place of business at [insert: address of Supplier] (hereinafter called “the Supplier”).

WHEREAS the Purchaser invited bids for certain Goods and ancillary services, viz., [insert brief description of Goods and Services] and has accepted a Bid by the Supplier for the supply of those Goods and Services in the sum of [insert Contract Price in words and figures, expressed in the Contract currency(ies)] (hereinafter called “the Contract Price”).

NOW THIS AGREEMENT WITNESSETH AS FOLLOWS:

01. In this Agreement words and expressions shall have the same meanings as are respectively assigned to them in the Conditions of Contract referred to.
02. The following documents shall constitute the Contract between the Purchaser and the Supplier, and each shall be read and construed as an integral part of the Contract:

(a)	This Contract Agreement
(b)	General Conditions of Contract
(c)	Special Conditions of Contract
(d)	Technical Requirements (including Schedule of Requirements and Technical Specifications)
(e)	The Supplier’s Bid and original Price Schedules
(f)	The Purchaser’s Notification of Award
(g)	[Add here any other document(s)]

03. This Contract shall prevail over all other Contract documents. In the event of any discrepancy or inconsistency within the Contract documents, then the documents shall prevail in the order listed above.
04. In consideration of the payments to be made by the Purchaser to the Supplier as hereinafter mentioned, the Supplier hereby covenants with the Purchaser to provide the Goods and Services and to remedy defects therein in conformity in all respects with the provisions of the Contract.
05. The Purchaser hereby covenants to pay the Supplier in consideration of the provision of the Goods and Services and the remedying of defects therein, the Contract Price or such other sum as may become payable under the provisions of the Contract at the times and in the manner prescribed by the Contract.

IN WITNESS whereof the parties hereto have caused this Agreement to be executed in accordance with the laws of Union of India on the day, month and year indicated above.

For and on behalf of the Council of Scientific & Industrial Research

Signed : [insert signature]
in the capacity of [insert title or other appropriate designation]
in the presence of [insert identification of official witness]

Signed : [insert signature]
in the capacity of [insert title or other appropriate designation]
in the presence of [insert identification of official witness]

For and on behalf of the Supplier

Signed : [insert signature of authorized representative(s) of the Supplier]
in the capacity of [insert title or other appropriate designation]
in the presence of [insert identification of official witness]

CHAPTER 8

Other Standard Forms (To be enclosed as indicated below)

TABLE OF CONTENTS

Sl. No.	Name	Annexure
1	Bid Security Form (to be enclosed with the technical bid)	A
2	Bid Securing Declaration (to be enclosed with the technical bid)	B
3	Bidder Information Form (to be enclosed with the technical bid)	C
4	Manufacturer's Authorization Form (to be enclosed with the technical bid)	D
5	Performance Statement Form (to be enclosed with the technical bid)	E
6	Service Support Detail Form (to be enclosed with the technical bid)	F
7	Format of declaration of abiding by the code of integrity and conflict of interest to be submitted by the bidder (to be enclosed with the technical bid)	G
8	Deviation Statement Form (to be enclosed with the technical bid)	H
9	Bid Form (to be enclosed with the priced bid)	I
10	Performance Security Form (to be submitted on award of Contract)	J
11	Acceptance Certificate Form (to be submitted on award of Contract)	K
12	Integrity Pact (Not applicable) To be executed on Company's Letterhead duly stamped and signed	L

Note: Please refer clause 1.10.1 of the bidding documents for other documents to be attached with the bids/offers

BID SECURITY FORM

Whereas

(hereinafter called the tenderer)

has submitted their offer dated _____

for the supply of _____

(hereinafter called the tender)

Against the Purchaser's Tender No. _____

KNOW ALL MEN by these presents that WE _____

of _____ having our registered office at

_____ are bound unto _____ (hereinafter called the "Purchaser")

In _____ the _____ sum _____ of

For which payment will and truly to be made to the said Purchaser, the Bank binds itself, its successors and assigns by these presents. Sealed with the Common Seal of the said Bank this _____ day of _____ 20_____.

THE CONDITIONS OF THIS OBLIGATION ARE:

(1)	If the tenderer withdraws or amends or modifies or impairs or derogates from the Tender in any respect within the period of validity of this tender OR
(2)	If the tenderer having been notified of the acceptance of his tender by the Purchaser during the period of its validity
(a)	If the tenderer fails to furnish the Performance Security for the due Performance of the contract.
(b)	Fails or refuses to accept/execute the contract.

We undertake to pay the Purchaser up to the above amount upon receipt of its first written demand, without the Purchaser having to substantiate its demand, provided that in its demand the Purchaser will note that the amount claimed by it is due to it owing to the occurrence of one or both the two conditions, specifying the occurred condition or conditions.

This guarantee will remain in force up to and including 45 days after the period of tender validity and any demand in respect thereof should reach the Bank not later than the above date.

(Signature of the authorized officer of the Bank)

Name and designation of the officer
Seal, name & address of the Bank and address of the Branch

Note: Whenever the bidder chooses to submit the Bid Security in the form of Bank Guarantee, then he should advise the banker issuing the Bank Guarantee to immediately send by Registered Post (A.D.) an unstamped duplicate copy of the Guarantee directly to the Purchaser with a covering letter to compare with the original BG for the correctness, genuineness, etc.

Tender No.:

BID-SECURING DECLARATION FORM

Date: _____

Bid No. _____

To (insert complete name and address of the purchaser)

I/We. The undersigned, declare that:

I/We understand that, according to your conditions, bids must be supported by a Bid Securing Declaration.

I/We accept that I/We may be disqualified from bidding for any contract with you for a period of one year from the date of notification if I am /We are in a breach of any obligation under the bid conditions, because I/We

(a)	have withdrawn/modified/amended, impairs or derogates from the tender, my/our Bid during the period of bid validity specified in the form of Bid; or
(b)	having been notified of the acceptance of our Bid by the purchaser during the period of bid validity <ul style="list-style-type: none"> (i) fail or reuse to execute the contract, if required, or (ii) fail or refuse to furnish the Performance Security, in accordance with the Instructions to Bidders.

I/We understand this Bid Securing Declaration shall cease to be valid if I am/we are not the successful Bidder, upon the earlier of (i) the receipt of your notification of the name of the successful Bidder; or (ii) thirty days after the expiration of the validity of my/our Bid.

Signed: (insert signature of person whose name and capacity are shown)
in the capacity of (insert legal capacity of person signing the Bid Securing Declaration).

Name: (insert complete name of person signing the Bid Securing Declaration)

Duly authorized to sign the bid for an on behalf of : (insert complete name of Bidder)

Dated on _____ day of _____(insert date of signing)

Corporate Seal (where appropriate)

(Note: In case of a Joint Venture, the Bid Securing Declaration must be in the name of all partners to the Joint Venture that submits the bid)

BIDDER INFORMATION FORM

- (a) [The Bidder shall fill in this Form in accordance with the instructions indicated below. No alterations to its format shall be permitted and no substitutions shall be accepted. This should be done of the letter head of the firm]

Date : [insert date (as day, month and year) of Bid Submission]

Tender No : [insert number from Invitation for bids]

01.	Bidder's Legal Name [insert Bidder's legal name]
02.	In case of JV, legal name of each party: [insert legal name of each party in JV]
03.	Bidder's actual or intended Country of Registration: [insert actual or intended Country of Registration]
04.	Bidder's Year of Registration: [insert Bidder's year of registration]
05.	Bidder's Legal Address in Country of Registration: [insert Bidder's legal address in country of registration]
06.	Bidder's Authorized Representative Information Name: [insert Authorized Representative's name] Address: [insert Authorized Representative's Address] Telephone/Fax numbers: [insert Authorized Representative's telephone/fax numbers] Email Address: [insert Authorized Representative's email address]
07.	Attached are copies of original documents of: Articles of Incorporation or Registration of firm named in 1, above.

Signature of Bidder _____

Name _____

Business Address _____

MANUFACTURERS' AUTHORIZATION FORM

[The Bidder shall require the Manufacturer to fill in this Form in accordance with the instructions indicated. This letter of authorization should be on the letterhead of the Manufacturer and should be signed by a person with the proper authority to sign documents that are binding on the Manufacturer.]

Date : *[insert date (as day, month and year) of Bid Submission]*

Tender No. : *[insert number from Invitation For Bids]*

To : *[insert complete name and address of Purchaser]*

WHEREAS

We *[insert complete name of Manufacturer]*, who are official manufacturers of *[insert type of goods manufactured]*, having factories at *[insert full address of Manufacturer's factories]*, do hereby authorize *[insert complete name of Bidder]* to submit a bid the purpose of which is to provide the following Goods, manufactured by us *[insert name and or brief description of the Goods]*, and to subsequently negotiate and sign the Contract.

We hereby extend our full guarantee and warranty in accordance with Clause 2.20 of the General Conditions of Contract, with respect to the Goods offered by the above firm.

Signed: *[insert signature(s) of authorized representative(s) of the Manufacturer]*

Name: *[insert complete name(s) of authorized representative(s) of the Manufacturer]*

Title: *[insert title]*

Duly authorized to sign this Authorization on behalf of: *[insert complete name of Bidder]*

Dated on _____ day of _____, _____ *[insert date of signing]*

PERFORMANCE STATEMENT FORM

Details of similar equipment / systems supplied & installed during past 3 years in India & Abroad

Tender No.:

Name of the Bidder _____

Order Placed by (full address of Purchaser)	Order No. and date	Description and quantity of ordered equipment	Value of order	Date of completion of deliver as per contract	Date of actual completion of delivery	Remarks indicating reasons for late delivery, if any	Has the equipment been installed/ working satisfactory? (Attach a certificate from the purchaser / Consignee)	Name of Contact person along with Telephone No., Fax No. and e-mail address

Signature and Seal of the manufacturer/Bidder

Place :

Date :

Tender No.:

SERVICE SUPPORT DETAIL FORM

Sr. No.	List of similar type of equipment's serviced in the past 3 years	Address, Telephone Nos., Fax No. and e-mail address of the buyer	Nature of training Imparted/ service provided	Name and address of service provider

Signature and Seal of the manufacturer/Bidder.....

Place :

Date :

Format for declaration by the Bidder for Code of Integrity & conflict of interest
(On the Letter Head of the Bidder)

Ref. No: _____

Date _____

To,

(Name & address of the Purchaser)

Sir/Madam,

With reference to your Tender No. _____ dated _____ I/We hereby declare that we shall abide by the Code of Integrity for Public Procurement as mentioned under Para 1.3.0 of ITB of your Tender document and have no conflict of interest.

The details of any previous transgressions of the code of integrity with any entity in any country during the last three years or of being debarred by any other Procuring Entity are as under:

- a
- b
- c

We undertake that we shall be liable for any punitive action in case of transgression/ contravention of this code.

Thanking you,

Yours sincerely,

Signature
(Name of the Authorized Signatory)
Company Seal

Tender No.:

DEVIATION STATEMENT FORM**PART –I**

The following are the particulars of deviations from the requirements of the tender specifications:

Sl.No.	Name of Specifications/ Parts/Accessories of Tender Enquiry	Specifications of quote Model / Part / Accessory	Compliance whether YES/NO	Deviation, if any to be indicated in unambiguous terms (The compliance/ Deviation should be supported by relevant Technical Literature)	Technical justification for the deviation, if any. If specification is superior / inferior than asked for in the enquiry, it should be clearly brought out in the justification

Signature of Bidder

- If the Bidder offers more than one model, then the Compliance Statement must be enclosed for each and every model separately.
- The Technical and Commercial deviations should be indicated separately.
- If the Bidder fails to enclose the compliance statement, his bid is likely to be rejected.

Place:

Date:

Signature and seal of the Manufacturer/Bidder

NOTE:

Where there is no deviation, the statement should be returned duly signed with an endorsement indicating **“No Deviations”**.

Tender No.:

PART - II**(Refer Clause 1.26 of Tender Document, Chapter-6 & Chapter-7)**

Sr. No.	Tender Clause No./ Chapter/Annexure	Tender Requirement	Compliance	Document Submitted
1	ITB 1.18	Bid is Signed	Yes / No	Yes / No
2	ITB 1.17	Bid Validity (90 days after the date of Bid opening)	Yes / No Bid Valid up to	Yes / No
3	ITB 1.16 Chapter 8:Annexure A	EMD (to be valid till 45 days beyond the validity of Bid)	Yes / No	Yes / No
4	Chapter-8, Annexure-B	Bid Securing Declaration Form	Yes / No	Yes / No
5	Chapter 8: Annexure -C	Bidder Information Form enclosed	Yes / No	Yes / No
6	Chapter 8: Annexure-D	Manufacturers Authorisation Form (MAF) (If Applicable) enclosed	Yes / No	Yes / No
7	Chapter 8 - Annexure E	Performance Statement Form enclosed	Yes / No	Yes / No
8	Chapter 8: Annexure F	Service Support details enclosed	Yes / No	Yes / No
9	Chapter 8: Annexure-G	Declaration-Code of Integrity	Yes / No	Yes / No
10	Chapter 8:Annexure H - Part I & Part II	Deviation Statement Form enclosed	Yes / No	Yes / No
11	Chapter 8: Annexure-I	Bid Form (To be enclosed with price schedule)	Yes / No	Yes / No
12	Chapter 8: Annexure L	Integrity Pact	Yes / No	Yes / No
13	GCC/SCC 2.21	Warranty: As per SCC & Chapter-4	Yes / No	Yes / No
14	GCC/SCC 2.13	Agree to submit Performance Security 3% of PO Value	Yes / No	Yes / No

The Bidder should submit other documents such as fulfillment of financial qualification criteria, Schedule of Requirement (Chapter-3) and various forms as specified in Chapter-8.

Bid Form

[The Bidder shall fill in this Form in accordance with the instructions indicated No alterations to its format shall be permitted and no substitutions shall be accepted.]

Date : [insert date (as day, month and year) of Bid Submission]

Tender No. :

To : Director, CSIR-NAL, Bengaluru

We, the undersigned, declare that:

(a)	We have examined and have no reservations to the Bidding Documents, including Addenda No.: [insert the number and issuing date of each Addenda]
(b)	We offer to supply in conformity with the Bidding Documents and in accordance with the Delivery Schedules specified in the Schedule of Requirements the following Goods and Related Services [insert a brief description of the Goods and Related Services] as specified in Chapter 4
(c)	The total price of our Bid, excluding any discounts offered in item (d) below, is: [insert the total bid price in words and figures, indicating the various amounts and the respective currencies]
(d)	The discounts offered and the methodologies for their application are: Discounts. If our bid is accepted, the following discounts shall apply. [Specify in detail each discount offered and the specific item of the Schedule of Requirements to which it applies.]
(e)	Our bid shall be valid for the period of time specified in ITB Clause 1.17.1, from the date fixed for the bid submission due date in accordance with ITB Clause 1.19 and it shall remain binding upon us and may be accepted at any time before the expiration of that period
(f)	If our bid is accepted, we commit to obtain a performance security in accordance with ITB Clause 1.43 and GCC Clause 2.13 for the due performance of the Contract and also submit order acceptance within 14 days from the date of contract in accordance with ITB Clause 1.42 and GCC Clause 2.44;
(g)	The following commissions, gratuities, or fees have been paid or are to be paid with respect to the bidding process or execution of the Contract: [insert complete name of each Recipient, its full address, the reason for which each commission or gratuity was paid and the amount and currency of each such commission or gratuity]

Name of Recipient	Address	Reason	Amount
_____	_____	_____	_____
_____	_____	_____	_____
_____	_____	_____	_____

(If none has been paid or is to be paid, indicate "none.")

(h)	We understand that this bid, together with your written acceptance thereof included in your notification of award, shall constitute a binding contract between us, until a formal contract is prepared and executed.
(i)	We understand that you are not bound to accept the lowest evaluated bid or any other bid that you may receive.

Signed : [insert signature of person whose name and capacity are shown]

In the capacity of [insert legal capacity of person signing the Bid Submission Form]

Name : [insert complete name of person signing the Bid Submission Form]

Duly authorized to sign the bid for and on behalf of: [insert complete name of Bidder]

Dated on _____ day of _____, _____ [insert date of signing]

Tender No.:

PERFORMANCE SECURITY FORM/STAND-BY LETTER OF CREDIT

MODEL BANK GUARANTEE FORMAT FOR PERFORMANCE SECURITY/ STAND-BY LETTER OF CREDIT

To,

.....

WHEREAS (name and address of the supplier) (hereinafter called "the supplier") has undertaken, in pursuance of contract No. datedto supply (description of goods and services) (herein after called "the contract").

AND WHEREAS it has been stipulated by you in the said contract that the supplier shall furnish you with a bank guarantee by a scheduled commercial bank recognized by you for the sum specified therein as security for compliance with its obligations in accordance with the contract;

AND WHEREAS we have agreed to give the supplier such a bank guarantee;

NOW THEREFORE we hereby affirm that we are guarantors and responsible to you, on behalf of the supplier, up to a total of (amount of the guarantee in words and figures), and we undertake to pay you, upon your first written demand declaring the supplier to be in default under the contract and without cavil or argument, any sum or sums within the limits of (amount of guarantee) as aforesaid, without your needing to prove or to show grounds or reasons for your demand or the sum specified therein.

We hereby waive the necessity of your demanding the said debt from the supplier before presenting us with the demand.

We further agree that no change or addition to or other modification of the terms of the contract to be performed there under or of any of the contract documents which may be made between you and the supplier shall in any way release us from any liability under this guarantee and we hereby waive notice of any such change, addition or modification.

This guarantee shall be valid until the day of, 20.....

(Signature of the authorized officer of the Bank)

.....

Name and designation of the officer

.....

Seal, Name & Address of the Issuing Branch of the Bank

Note:

Whenever, the bidder chooses to submit the Performance Security in the form of Bank Guarantee, then he should advise the banker issuing the Bank Guarantee to immediately send by Registered Post (A.D.) an unstamped duplicate copy of the Guarantee directly to the Purchaser with a covering letter to compare with the original BG for the correctness, genuineness, etc.

Acceptance Certificate				Annexure-K	
PO No. NAL/PUR/			Date:		
Sub: Certificate of Supply, Installation, Commissioning, Training and Acceptance of Goods & Services					
1	This is to certify that the equipment as detailed below has/have been received in good condition along with all the standard and special accessories (subject to remarks in Para 2). The same has been installed, commissioned and accepted.				
(a)	Contract No.				
	Date				
	Value				
	Mode of Shipment				
(b)	Description of the Equipment				
(c)	Name of the Consignee		CSIR-NAL, Bengaluru		
(d)	Scheduled date of Delivery of the Consignment to the Laboratory/Institute				
(e)	Details of LC Established				
	Date of Establishment		Date of Shipment		Date of Expiry
(f)	Actual date of receipt of Consignment by the Laboratory/Institute				
	Date of Shipment		Date of Receipt at CSIR-NAL		
(g)	Scheduled date for completion of Installation, Commissioning and acceptance				
(h)	Actual date of completion of Installation, Commissioning and acceptance				
(i)	Penalty for Late Delivery (at Laboratory / Institute level) Rs.				
(j)	Penalty for Late Installation, Commissioning and Acceptance (at Laboratory / Institute level) Rs.				
2	Details of accessories/items not yet supplied and recoveries to be made on that account				
Sr. No.	Description			Amount to be recovered	
3	The acceptance test has been done to our entire satisfaction. The Supplier has fulfilled his contractual obligations satisfactory - Yes				
	OR				
	The Supplier has failed to fulfill his contractual obligations with regard to the following:				
Sr. No.	Description			Amount to be recovered	
The amount of recovery on account of failure of the supplier to meet his contractual obligations is as indicated at Para 3					
4	Liquidated Damages/Penalty Percentage		(a) If the Supplier fails to Supply, Install and Commission the system as per specifications mentioned in the order within the due date including training, the Supplier is liable to pay penalty of 0.5% of order value per week or part of a week. (b) The maximum amount of penalty shall be 10%		
	No. of Days / Weeks delayed		Amount to be recovered		
5	Warranty Details				
6	Training, if any		COMPLETED/ NOT COMPLETED (attach training Certificate/document, if any)		
7	Details of Performance Security submitted in the form of Bank Guarantee / Demand Draft				
	BG No.	Date	Amount In Rs.	Valid till	% of BG
For Purchaser (Indenting Officer)			For Purchaser (Project Leader)		
Signature		Signature			
Name		Name			
Designation		Designation			
Name of the Laboratory/Institute		CSIR-NAL		Name of the Laboratory/Institute	
Date		Date			
For Supplier					
Signature		66			
Name					
Designation					
Name of the					

FORMAT OF INTEGRITY PACT
INTEGRITY PACT

Tender No.:

Between

Council of Scientific & Industrial Research (CSIR) a Society registered under the Indian Societies Act 1860 represented by _____ hereinafter referred to as "The Principal".

Andherein referred to as "The Bidder/ Contractor."

Preamble

The Principal intends to award, under laid down organizational procedures, contract/s forThe Principal values full compliance with all relevant laws of the land, rules, regulations, economic use of resources and of fairness/ transparency in its relations with its Bidder(s) and/or Contractor(s).

In order to achieve these goals, the Principal will appoint an Independent External Monitor (IEM), who will monitor the tender process and the execution of the contract for compliance with the principles mentioned above.

Section 1 – Commitments of the Principal

- (1) The Principal commits itself to take all measures necessary to prevent corruption and to observe the following principles:
 - (a) No employee of the Principal, personally or through family members, will in connection with the tender for, or the execution of a contract, demand, take a promise for or accept, for self or third person, any material or immaterial benefit which the person is not legally entitled to.
 - (b) The Principal will, during the tender process treat all Bidder(s) with equity and reason. The Principal will in particular, before and during the tender process, provide to all Bidder(s) the same information and will not provide to any Bidder(s) confidential/additional information through which the Bidder(s) could obtain an advantage in relation to the tender process or the contract execution.
 - (c) The Principal will exclude from the process all known prejudiced persons.
- (2) If the Principal obtains information on the conduct of any of its employees which is a criminal offence under the IPC/PC Act, or if there be a substantive suspicion in this regard, the Principal will inform the Chief Vigilance Officer and in addition can initiate disciplinary action.

Section 2 – Commitments of the Bidder(s)/Contractor(s)

- (1) The Bidder(s)/Contractor(s) commit himself to take all measures necessary to prevent corruption. He commits himself to observe the following principles during his participation in the tender process and during the contract execution.
 - (a) The Bidder(s)/Contractor(s) will not, directly or through any other Person or firm, offer, promise or give to any of the Principal's employees involved in the tender process or the execution of the contract or to any third person any material or other benefit which he/she is not legally entitled to, in order to obtain in exchange any advantage of any kind whatsoever during the tender process or during the execution of the contract.
 - (b) The Bidder(s)/Contractor(s) will not enter with other Bidders into any undisclosed agreement or understanding, whether formal or informal. This applies in particular to prices, specifications, Certifications, subsidiary contracts, submission or non-submission of bids or any other actions to restrict competitiveness or to introduce cartelization in the bidding process.

- (c) The Bidder(s)/Contractor(s) will not commit any offence under the relevant IPC/PC Act; further the Bidder(s)/Contractor(s) will not use improperly, for purposes of competition or personal gain, or pass on to others, any information or document provided by the Principal as part of the business relationship, regarding plans, technical proposals and business details, including information contained or transmitted electronically.
- (d) The Bidder(s)/Contractor(s) of foreign origin shall disclose the name and address of the Agents/representatives in India, if any. Similarly, the Bidder(s)/Contractor(s) of Indian Nationality shall furnish the name and address of the foreign principals, if any. Further details as mentioned in the “Guidelines on Indian Agents of Foreign Suppliers” shall be disclosed by the Bidder(s)/Contractor(s). Further, as mentioned in the Guidelines all the payments made to the Indian agent/representative have to be in Indian Rupees only. Copy of the “Guidelines on Indian Agents of Foreign Suppliers” is annexed and marked as Annexure.
- (e) The Bidder(s)/Contractor(s) will, when presenting his bid, disclose any and all payments he has made, is committed to or intends to make to agents, brokers or any other intermediaries in connection with the award of the contract.
- (2) The Bidder(s)/Contractor(s) will not instigate third persons to commit offences outlined above or be an accessory to such offences.
- (3) The person signing IP shall not approach the courts while representing the matters to IEMs and he/she will await their decision in the matter.

Section 3 – Disqualification from tender process and exclusion from future Contracts

- (1) If the Bidder(s)/Contractor(s), before award or during execution has committed a transgression through a violation of Section 2, above or in any other form such as to put his reliability or credibility in question, the Principal is entitled to disqualify the Bidder(s)/Contractor(s) from the tender process or take action as per the procedure mentioned in the “Guidelines on Banning of business dealings”. Copy of the “Guidelines on Banning of business dealings” is annexed and marked as Annex -“B”.

Section 4 – Compensation for Damages

- (1) If the Principal has disqualified the Bidder(s) from the tender process prior to the award according to Section 3, the Principal is entitled to demand and recover the damages equivalent to Earnest Money Deposit/ Bid Security.
- (2) If the Principal has terminated the contract according to Section 3, or if the Principal is entitled to terminate the contract according to Section 3, the Principal shall be entitled to demand and recover from the Contractor liquidated damages of the contract value or the amount equivalent to Performance Bank Guarantee.

Section 5 – Previous transgression

- (1) The Bidder declares that no previous transgressions occurred in the last 3 Years with any other Company in any country conforming to the anti-corruption approach or with any other Public Sector Enterprise in India that could justify his exclusion from the tender process.
- (2) If the Bidder makes incorrect statement on this subject, he can be disqualified from the tender process or action can be taken as per the procedure mentioned in “Guidelines on Banning of business dealings.”

Section 6 – Equal treatment of all Bidders / Contractors/ Sub-contractors

- (1) The Bidder(s)/Contractor(s) undertake(s) to demand from all Subcontractors a commitment in conformity with this Integrity Pact, and to submit it to the Principal before contract signing.
- (2) The Principal will enter into agreements with identical conditions as this one with all Bidders, Contractors and Subcontractors.
- (3) The Principal will disqualify from the tender process all bidders who do not sign this Pact or violate its provisions.

Section 7 – Criminal charges against violating Bidders / Contractors/ Subcontractors

- (1) If the Principal obtains knowledge of conduct of a bidder, Contractor or Subcontractor or of an employee or a representative or an associate of a bidder, Contractor or Subcontractor which constitutes corruption, or if the Principal has substantive suspicion in this regard, the Principal will inform the same to the Chief Vigilance Officer.

Section 8 - Independent External Monitors

- (1) The Principal appoints competent and credible Independent External Monitor for this Pact. The task of the Monitor is to review independently and objectively, whether and to what extent the parties comply with the obligations under this agreement.
- (2) The Monitor is not subject to instructions by the representatives of the parties and performs his functions neutrally and independently. He reports to the JS (A), CSIR.
- (3) The Bidder(s)/Contractor(s) accepts that the Monitor has the right to access without restriction to all Project documentation of the Principal including that provided by the Contractor. The Contractor will also grant the Monitor, upon his request and demonstration of a valid interest, unrestricted and unconditional access to his project documentation. The same is applicable to Subcontractors. The Monitor is under contractual obligation to treat the information and documents of the Bidder(s)/ Contractor(s) / Subcontractor(s) with confidentiality.
- (4) The Principal will provide to the Monitor sufficient information about all meetings among the parties related to the Project provided such meetings could have an impact on the contractual relations between the Principal and the Contractor. The parties offer to the Monitor the option to participate in such meetings.
- (5) As soon as the Monitor notice, or believes to notice, a violation of this agreement, he will so inform the Management of the Principal and request the Management to discontinue or take corrective action, or to take other relevant action. The monitor can in this regard submit non-binding recommendations. Beyond this, the Monitor has no right to demand from the parties that they act in a specific manner, refrain from action or tolerate action.
- (6) The Monitor will submit a written report to the JS(A), CSIR within 8 to 10 weeks from the date of reference or intimation to him by the Principal and should the occasion arise, submit proposals for correcting problematic situations.
- (7) Monitor shall be entitled to compensation on the same terms as being extended to/provided to Independent Directors on the CSIR.
- (8) If the Monitor has reported to the JS(A), CSIR, a substantiated suspicion of an offence under relevant IPC/PC Act, and the JS(A), CSIR has not, within the reasonable time taken visible action to proceed against such offence or reported it to the Chief Vigilance Officer, the Monitor may also transmit this information directly to the Central Vigilance Commissioner.
- (9) The word 'Monitor' would include both singular and plural.

Section 9 – Pact Duration

This Pact begins when both parties have legally signed it. It expires for the Contractor 10 months after the last payment under the contract, and for all other Bidders 6 months after the contract has been awarded.

If any claim is made/lodged during this time, the same shall be binding and continue to be valid despite the lapse of this pact as specified above, unless it is discharged/determined by JS(A), CSIR.

Section 10 – Other provisions

- (1) This agreement is subject to Indian Law. Place of performance and Jurisdiction is the Registered Office of the Principal, i.e. New Delhi
- (2) Changes and supplements as well as termination notices need to be made in writing. Side agreements have not been made.
- (3) If the Contractor is a partnership or a consortium, this agreement must be signed by all partners or consortium members.
- (4) Should one or several provisions of this agreement turn out to be invalid, the remainder of this agreement remains valid. In this case, the parties will strive to come to an agreement to their original intentions.

(For & On behalf of the Principal)
(Office Seal)

(For & On behalf of Bidder/Contractor)
(Office Seal)

Place.....

Place.....

Date.....

Date.....

Witness 1:(Name & Address): _____

Witness 2:(Name & Address): _____