

# Regional Transport Aircraft (RTA)

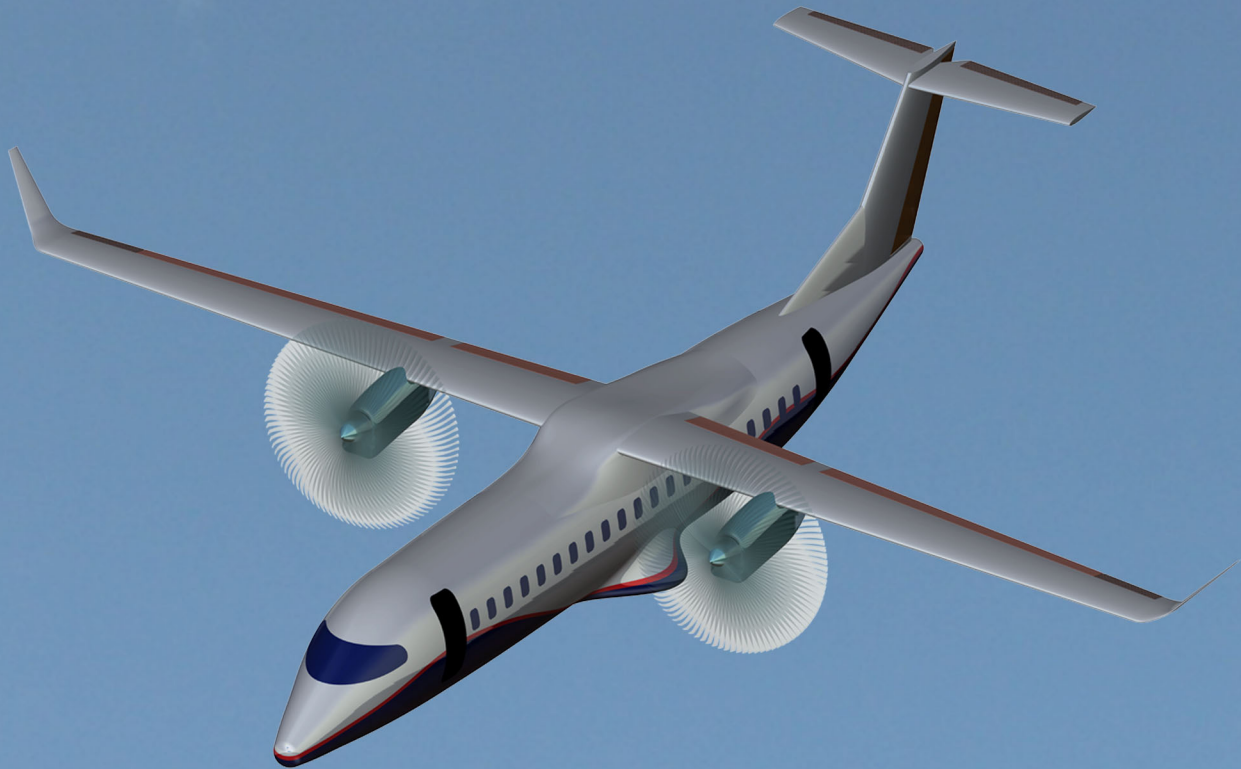

## Salient Features

### TARGETS

#### Operational Economics

- Lower acquisition cost 25% lower
- Lower direct operating cost 25% lower
- Lower maintenance cost 50% lower

#### Performance

- Operations from unequipped airfields
- All weather operation
- Low Noise Level (FAR-36 stage 4)
- Cargo hold for additional payload
- Lower emissions

### SPECIFICATIONS

- Payload : Baseline : 70 pax + 1000 kg cargo  
Stretch : 90 pax + 1000 kg cargo
- Range with maximum pax – 2000 km (1080 nm)
- Range with maximum fuel (50 pax) – 3800 km (2050 nm)
- Takeoff balanced field length (ISA+15°C, SL, MTOW) – 1100 m
- Approach speed (MLW) – 110 kts
- Ceiling – 9144 m (30,000 ft)
- Cruise speed – 550 kmph TAS (300 kts)
- Avionics and FCS-Open architecture, COTS, FBW, GPS, ADS, Low cost HUD, etc.
- Noise level – FAR36 stage IV
- Wide cabin 4 abreast arrangement
- Cargo hold volume 14 m<sup>3</sup>



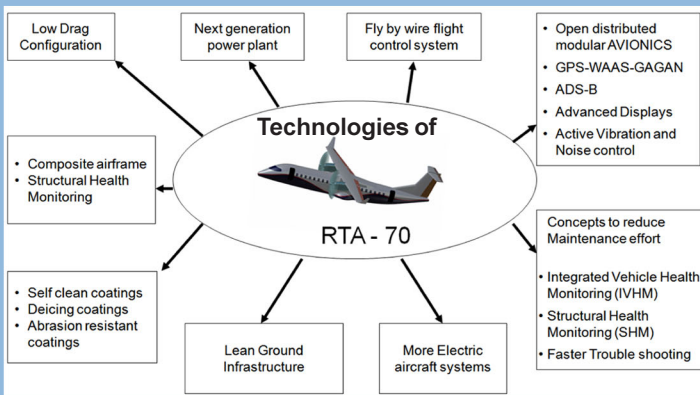
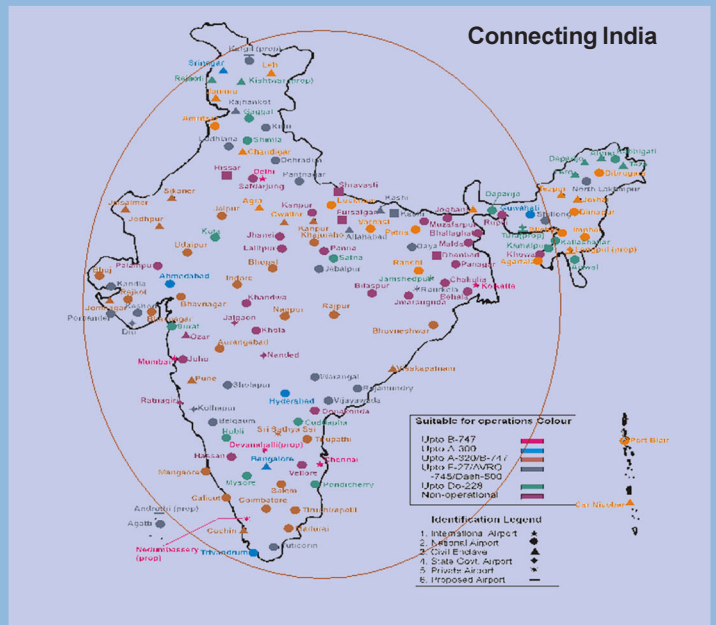
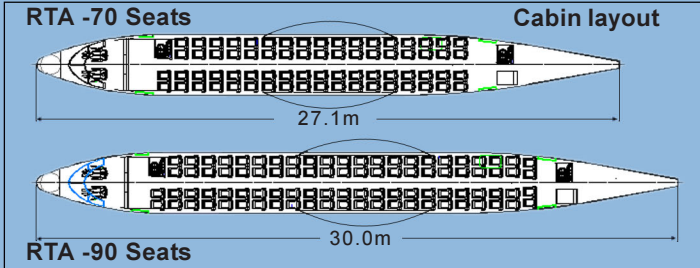
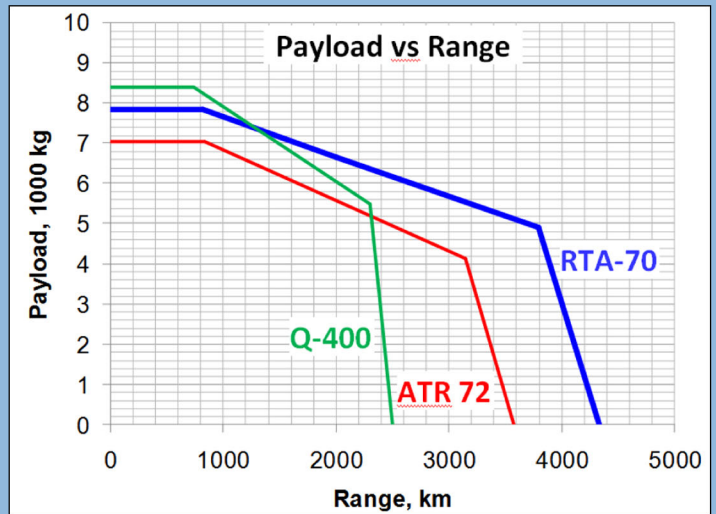
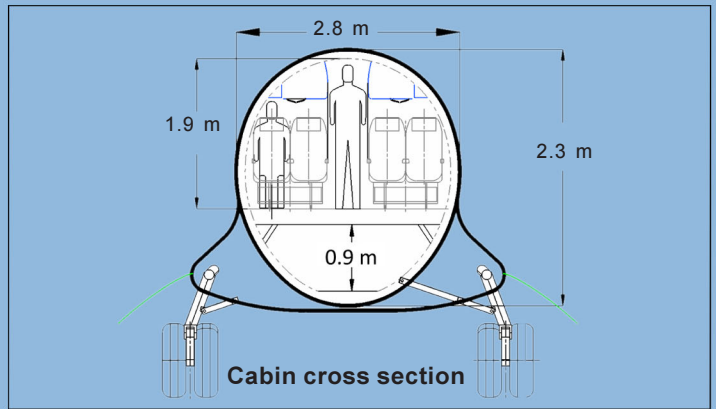
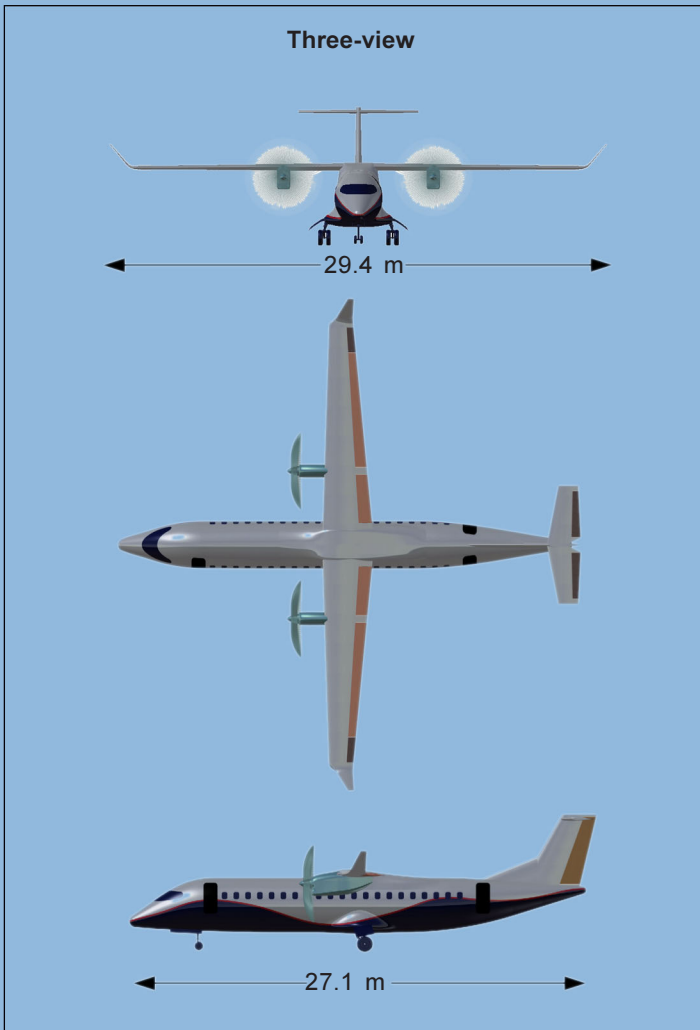

For more information contact:  
 Director  
 Council of Scientific & Industrial Research  
 National Aerospace Laboratories  
 PB 1779, Bangalore 560 017, India.  
 Tel: 25270584, 25265579  
 www.nal.res.in